



Fluorescent "T-Bar" Power Pack with Maintenance-Free Nickel Cadmium Battery

AM-L Will light 1 lamp in a 2 lamp
fluorescent fixture

AM-L -2 Will light 2 lamps in a 4 lamp
fluorescent fixture



application Designed for easy installation into T-Bar grid ceiling adjoining fluorescent fixture. Will convert any new or existing 2, 4, 6 or 8 ft. fluorescent fixture into instantaneous emergency lighting.

features

- Unit consists of an AM7 fluorescent pack secured to upper surface (interior) of a metal panel.
- AM-L will light one lamp in any 2, 4, 6 or 8 ft. fluorescent fixture. AM-L-2 will light two lamps in any four lamp 2, 4, 6 or 8 ft. fluorescent fixture.
- Panel is installed into dropped ceiling, adjoining fluorescent fixture.
- Location of fluorescent pack outside of fixture eliminates heat problems and the need to fit pack into fixture channel.
- Test switch and pilot light are located on the lower surface (exterior) of the panel for easy access.
- Units can be easily wired to the fluorescent fixture according to the wiring diagram below.

AM-L wiring diagram

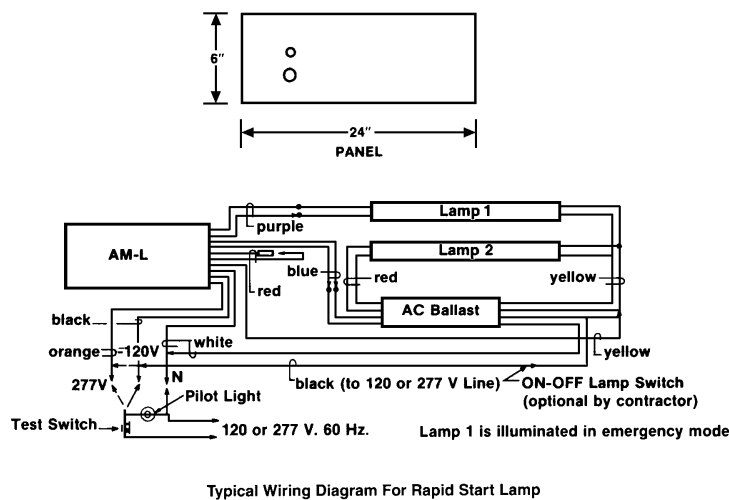

AM-L-2 wiring diagram

