

WLB Series

Compact wet location LED battery unit



BATTERY UNITS

Housing

- Thermoplastic housing
- Standard off-white finish

Mounting

- End mount
- Wall mount
- Universal J-box mounting
- Canopy included

Type of battery

- NI-MH Battery 3.6V 1500mAh

Lamp head source

- 1W white LED, 100 lumens

Electronics

- 120/277V, 50/60Hz
- Test switch and charge indicator

Approvals

- UL 924 listed
- Wet location -13°F to 104°F (-25°C to 40°C)
- UL 94 V-0 flame rating, fire-resistant
- IP65 rated
- Meets NEMA 3R specifications

Warranty (subject to proper installation and maintenance)

- Unit has a three year limited warranty

Detailed warranty terms located at: www.lightalarms.com



Photometric performance

Spacing center-to-center (feet)	
7' mounting height	15' mounting height
34.5'	28.25'

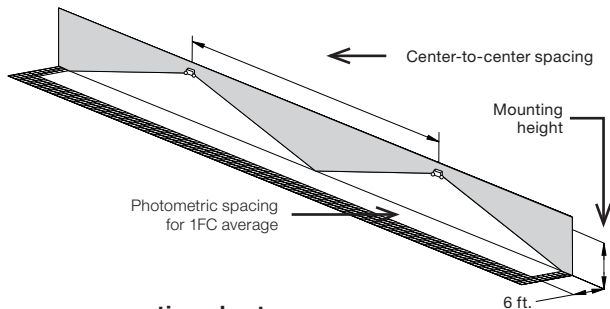

Power consumption chart

Model	Current (A) / Power (W)
WLB-2	120/277VAC, 60Hz 0.062/3

Dimensions (Dimensions are approximate and subject to change):

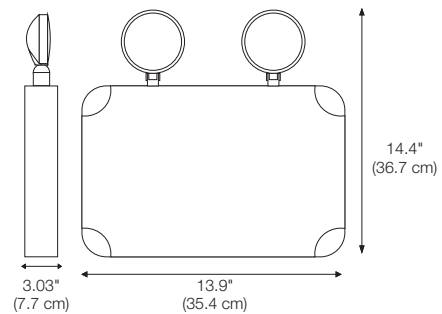

Ordering format

Series	Lamp
WLB= Battery unit	-2= 2 LED heads
Example: WLB-2	