

Nexus®Pro GATEWAY

Scan to download Nexus®Pro app for commissioning



IMPORTANT SAFEGUARDS

When using electrical equipment, basic safety precautions should always be taken including the following:

READ AND FOLLOW ALL SAFETY INSTRUCTIONS

1. All servicing should be performed by qualified service personnel.
2. All unused wires must be capped to prevent shorting.
3. Do not use outdoors.
4. Do not let power supply cords touch hot surfaces.
5. Do not mount near gas or electric heaters.
6. Equipment should be mounted in locations and at heights where it will not readily be subjected to tampering by unauthorized personnel.
7. Only use accessory equipment provided by the manufacturer for this product.
8. Make sure all cables, plugs and power supply are in good condition and meets all product requirements and standards.
9. Only connect the external power supply to a mating receptacle.
10. Only connect power to fully assembled Gateway once installation is complete per steps in this document.
11. Do not use this equipment for other than its intended use.
12. Unit to be installed only as per configuration described in this document.

WARNING:

- This document outlines general directives highlighting some safety and cautionary indications. Failing to respect these proposed methods (of installation, use and maintenance) could harm persons, damage devices or make them less safe.
 - This document is not intended as substitute for a suitable training, qualifications or experience with the safety procedures for this device.
 - For products provided with communication, the purchaser, the installer or the final customer is responsible for applying all the IT security measures to prevent risks arising from the connection to communication networks. Risks include, but are not limited to: the use of the product by unauthorized persons, the alterations of its normal operation, access to and modification of information.
 - The purchaser, installer and/or final customer have responsibility to ensure that the operating devices are safely locked, that safety warnings and notices are properly displayed and that all access points are secured.
 - All the information contained in this document is based on the latest information available at the time of publication. We reserve the right to modify the document without prior notice.
- For further information, explanations or specific problems contact your ABB sales representative.

It is suggested to place the Gateway in a central location in the facility. This will help to optimize RF communication of the emergency lighting network by eliminating any unnecessary distance with connected devices on the outside limit of the area coverage.

SAVE THESE INSTRUCTIONS

1. Turn off AC power.
2. The antennas supplied with this equipment must be installed as shown in Figure 1. The mating torque of the antennas must be 8 inch-pounds minimum and must not exceed a maximum of 10 inch-pounds.

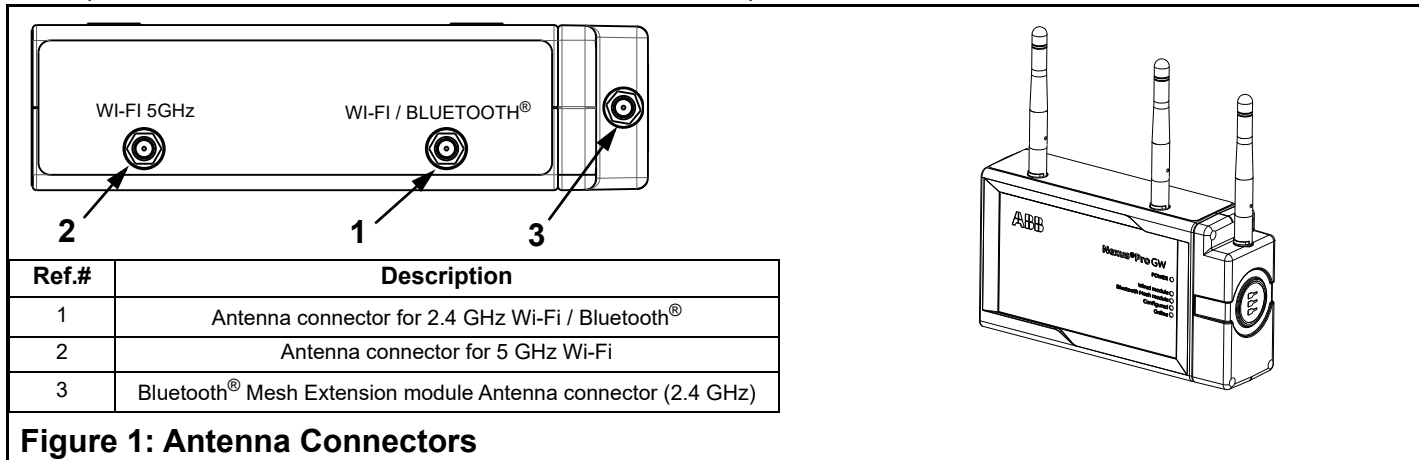

Ref.#	Description
1	Antenna connector for 2.4 GHz Wi-Fi / Bluetooth®
2	Antenna connector for 5 GHz Wi-Fi
3	Bluetooth® Mesh Extension module Antenna connector (2.4 GHz)

Figure 1: Antenna Connectors

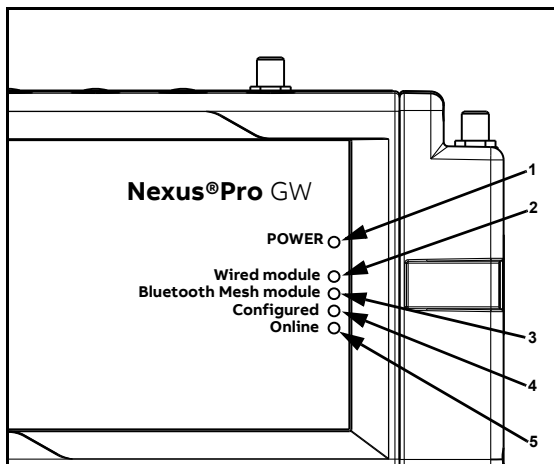

Ref.#	Use and Status	Color
1	Power: - LED ON: Product powered by the external source - LED OFF: Product not powered by the external source	Blue
2	Wired Module (N/A for NAM):	Amber
3	Bluetooth® Mesh Module: - LED ON: No fault detected on the wireless network - LED BLINKING: At least 1 fault is present on the wireless network - LED OFF: Wireless network is offline	Amber
4	Configured: - LED ON: Gateway is configured properly - LED BLINKING: At least 1 fault is present in the gateway - LED OFF: Gateway is not configured	Green
5	Online: - LED ON: Gateway is connected to the Cloud - LED BLINKING: Gateway has access to the intranet but not to the internet - LED OFF: Gateway is offline	Green

Note:
If LED 5 is Off and LED 4 is ON, the Gateway is working and connected to the Emergency Lighting units but is not connected to the Cloud.

Figure 2: LED indicator (Antennas not shown for clarity)

Installing DIN Rail

1. Determine mounting location of Gateway.
2. Using the screws and spacers supplied, install the DIN Rail as shown in figure 3.
 - a. Place DIN Rail in desired location on the mounting surface and mark 2 spots for screw position at the outer edges of the oblong openings.
 - b. Insert screw into spacer.
 - c. Using screws provided, attach DIN Rail to mounting surface.

Note: If attaching to other than wood surface, use alternative means to secure DIN RAIL.

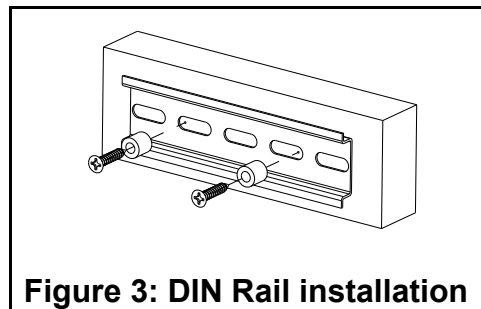

Figure 3: DIN Rail installation

Installing the Gateway to a DIN Rail

1. Ensure power is off.
2. Hook lower latch of DIN rail adapter mounting clip to lower edge of the DIN rail as shown in figure 4.
3. Lift Gateway up onto DIN rail and snap into top of the DIN rail adapter mounting clip as shown in figure 4. The upper latch of the DIN rail adapter mounting clip will lock onto the DIN rail when released.

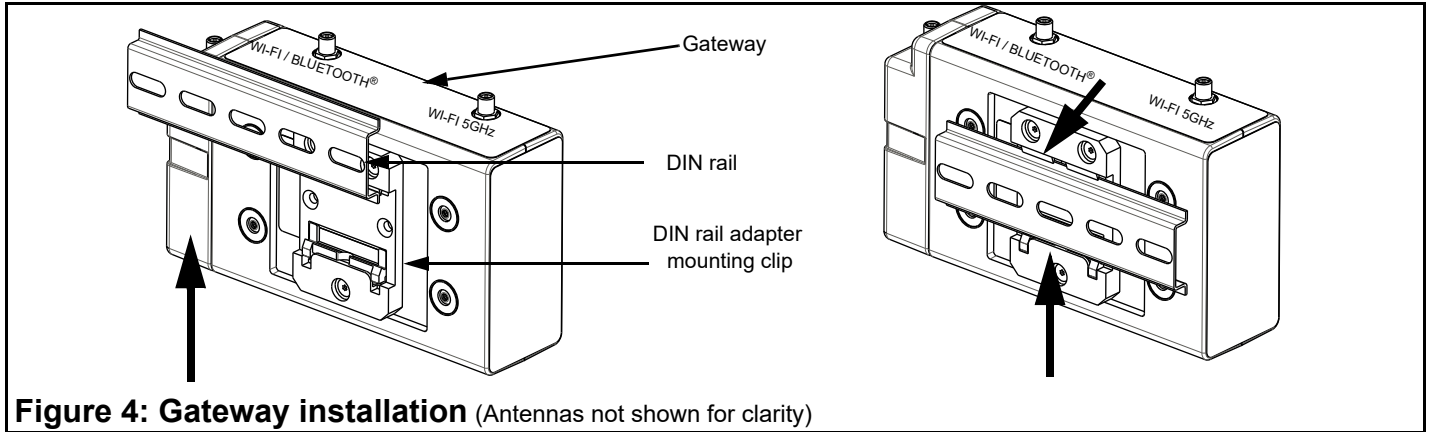

Figure 4: Gateway installation (Antennas not shown for clarity)

Removing the Gateway from a DIN Rail

1. Ensure power is off.
2. Pull up on the Gateway to release the upper latch of the DIN rail adapter mounting clip.
3. Tilt the upper part out to un-latch and lower the Gateway off the DIN rail.

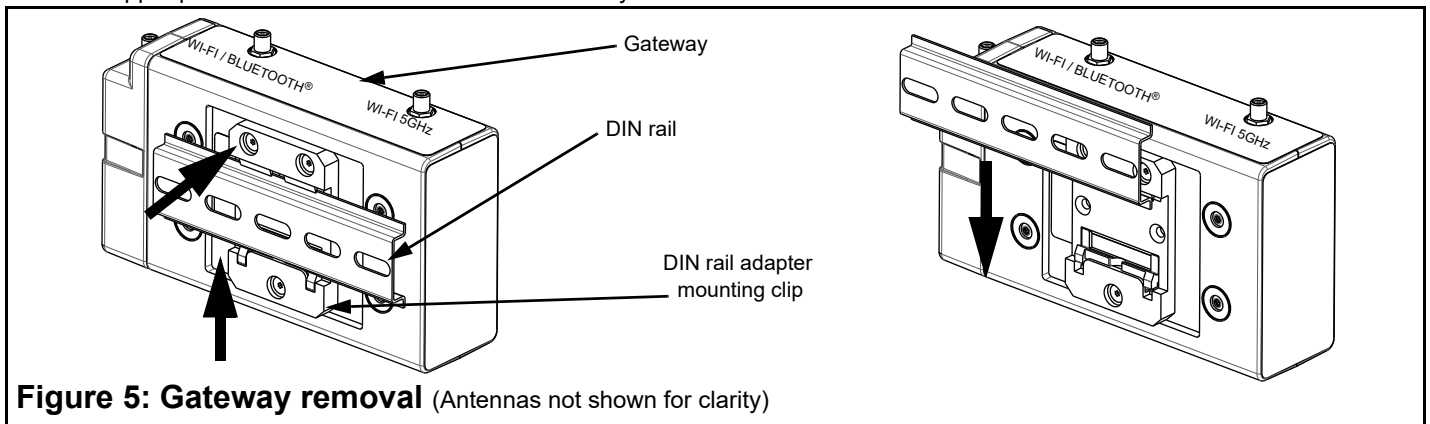

Figure 5: Gateway removal (Antennas not shown for clarity)

Supplying Power and Turning ON the Product

1. Using the supplied power adapter, plug the connector into the “Power in” connector on the bottom of the Gateway.
2. Plug the adapter into a standard wall receptacle.

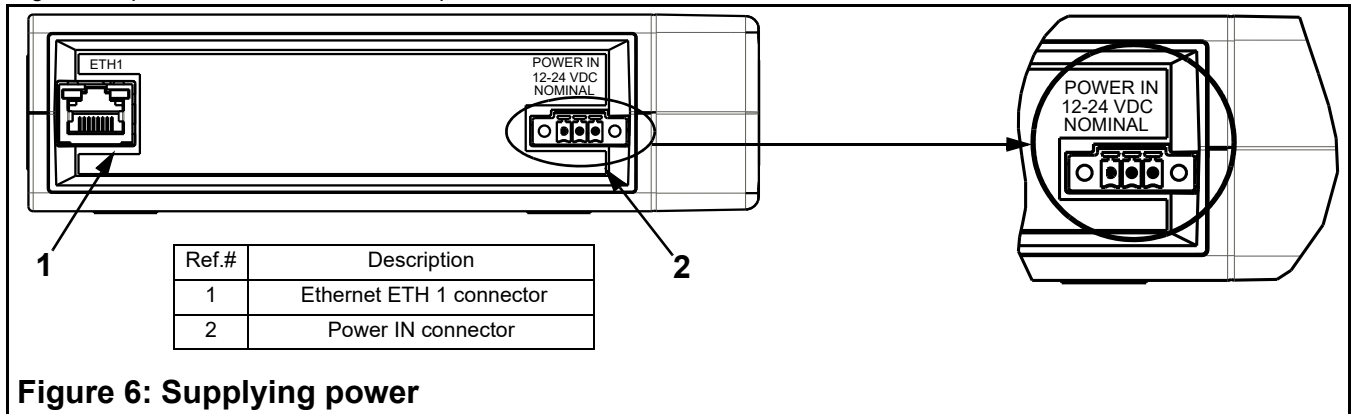

Figure 6: Supplying power

Cleaning the Product

1. Use water-based, non-flammable, cleaning products to remove dirt.
2. Use a dry, lint-free, cloth to remove dust.
3. Never use detergents, aerosol sprays, solvents or abrasive sponges.

FCC Statement

This device complies with part 15 of the FCC rules.

FCC ID: QQQBGM13P



CAUTION: The antennas must be installed such that a minimum separation distance of 2 inches(50.5mm) is maintained between the antennas and all persons at all times.

This equipment has been tested and found to comply with the limits for a Class B digital device, pursuant to Part 15 of the FCC rules. These limits are designed to provide reasonable protection against harmful interference in a residential installation. This equipment generates, uses, and can radiate radio frequency energy and, if not installed and used in accordance with the instructions, may cause harmful interference to radio communications. However, there is no guarantee that interference will not occur in a particular installation. If this equipment does cause harmful interference to radio or television reception, which can be determined by turning the equipment off and on, the user is encouraged to try to correct the interference by one or more of the following measures:

1. Reorient or relocate the receiving antenna.
2. Increase the separation between the equipment and receiver.
3. Connect the equipment to an outlet on a circuit different from that to which the receiver is connected.
4. Consult the dealer or an experienced radio/TV technician for help.



IMPORTANT: Changes or modifications not covered in this addendum must be approved in writing by the manufacturer. Changes or modifications made without written approval may void the user's authority to operate this equipment.

Innovation, Science and Economic Development Canada (ISED)

The term "ISED": before the certification/registration number only signifies that the Innovation, Science and Economic Development Canada technical specifications were met.

IC: 5123A-BGM13P

Non-Intentional Radiator: CAN ICES-005 (B) / NMB-005 (B)

Canadian Wireless Regulatory

This Class B digital apparatus meets all the requirements of the Canadian Interference Causing Equipment Regulations. This device contains license-exempt transmitter(s)/receiver(s) that comply with Innovation, Science and Economic Development Canada's license-exempt RRS(s). Operation is subject to the following two conditions: a) this device may not cause any interference, and b) this device must accept any interference, including interference that may cause undesired operation of the device. To prevent radio interference to the licensed service, this device is intended to be operated indoors, and away from windows to prevent maximum shielding. Equipment (or its transmit antenna) that is installed outdoors is subject to licensing.

Unauthorized Antenna Modifications

Use only the supplied integral antenna. Unauthorized antenna modifications or attachments could damage the unit and may violate FCC regulations. Any changes or modifications not expressly approved by the party responsible for compliance could void the user's authority to operate the equipment.



Precautions against electrostatic discharge (ESD)

Make sure to discharge any built-up static electricity from yourself and your electronic measurement devices before touching this equipment. The recommendation from the dealer is that you take this precaution before installation and connecting this equipment.

The Bluetooth® word mark and logo are registered trademarks owned by Bluetooth® SIG, Inc. and any use of such marks by ABB Inc. is under license. Other trademarks and trade names are those of their respective owners.

This product comes with a 5 year limited warranty. Refer to (www.lightalarms.com/warranty) for full warranty.

Contact information:

Nexus® Technical Support: ca-eml-nexus-techsupport@abb.com