

# Nexus®Pro Gateway



### Features

- IoT Gateway designed to deliver Bluetooth® Mesh connectivity
- Gateway can be connected wired or wirelessly to WiFi Routers
- One gateway required per building structure within Nexus®Pro<sup>1</sup>
- Each gateway communicates with up to 200 devices

<sup>1</sup>Note that multiple gateways can be physically installed in a building, supporting up to 200 emergency units each; however, in the Nexus®Pro app, gateways must be configured within separate digital building structures (e.g. if two gateways were installed in "Main Building", the gateways could be configured in the Nexus®Pro app as "Main Building 1" and "Main Building 2").

### Mounting

- Gateway supplied with a Din-rail that can also be used for wall installation

### Electronics

- Supplied with a 24VDC output
- Supports WiFi connections on both 2.4 GHz and 5 GHz frequency bands for added flexibility

### Approvals

- Suitable for installation indoors in a secure location  
32°F to 104°F (0°C to 40°C)
- RoHS compliant

**Warranty** (subject to proper installation and maintenance)

Five year full warranty

Detailed warranty terms located online at: [www.lightalarms.com](http://www.lightalarms.com)



**Dimensions** (Dimensions are approximate and subject to change):

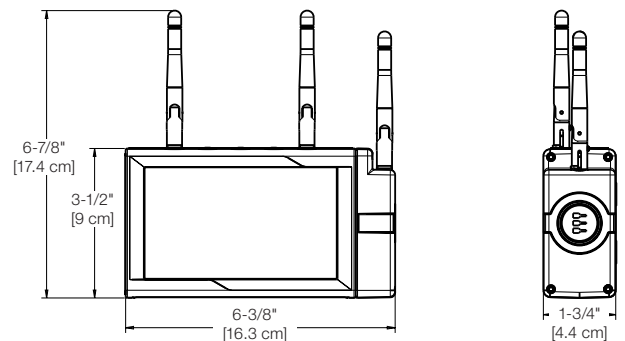

### Weight

Catalog number	Weight
NEXP-GATEWAY-LA	1 lb

### Power consumption

Catalog number	Power consumption
NEXP-GATEWAY-LA	4W typical, 15W maximum

### Ordering format

Catalog number	Description
NEXP-GATEWAY-LA	Nexus®Pro IoT Gateway