

LCA-2RHL Series

High output lithium LED battery unit



Housing

- UV stabilized thermoplastic body
- Two adjustable high output LED lighting heads
- White finish

Mounting

- Wall or ceiling mount
- Universal J-box mounting

Lamp type

- Two 9.6V-5.4W LED heads, 550 lumens per head

Electronics

- Pulse plus charger
- Low voltage disconnect
- Automatic brownout protection
- Battery lock-out
- Fused output circuit
- Standard Improved Diagnostics
- 120/277 60Hz

Battery type

- 9.6V Lithium phosphate battery

Photometric performance

Spacing center-to-center (feet)	
Mounting height	6 ft spacing distance
7.5'	90'
10'	78'

Approvals

- UL 924 Listed
- Damp location (50°F to 104°F)
- UL 94, 5VA flame rated
- Circle BC meet CEC title 20

Warranty (subject to proper installation and maintenance)

Unit: three-year full warranty

Detailed warranty terms located on **page 197 of the catalog** or online at: www.lightalarms.com

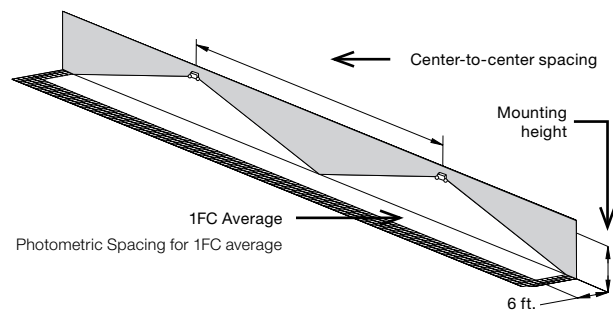

Dimensions (Dimensions are approximate and subject to change)

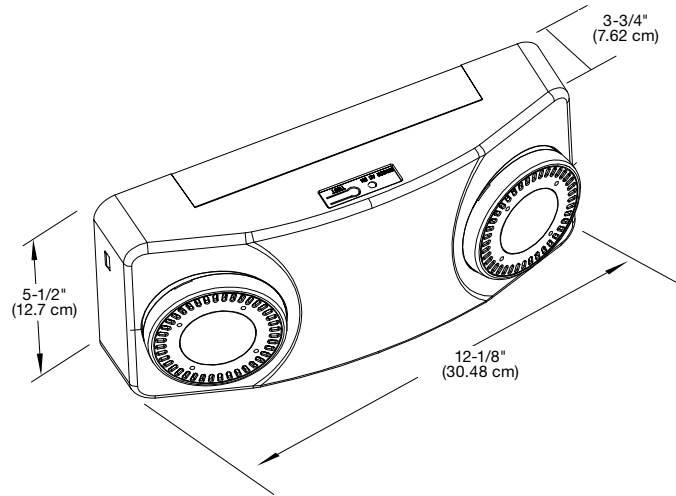

Power consumption chart

Series	DC Specs		AC Specs
	Battery	Voltage	Units dual voltage
LCA-2RHL-ID	Lithium-ion battery	9.6	120-277

Ordering format

Series	Heads
LCA	-2RHL-ID= Two round high output LED heads Improved Diagnostics

Example: LCA-2RHL-ID