

## CHB-2LR Series

Steel LED battery unit



Steel housing unit comes with two adjustable 6V-3.3W LED heads and a lead-calcium battery.

### Housing

- Constructed of 20-gauge steel
- Cabinet offered in mist white

### Mounting

- Knockouts on the back of unit for wall mount
- Side and top knockouts for conduit

### Heads

- Each unit comes with two adjustable 6V-3.3W LED heads
- Each unit provides 335 lumens

### Battery

- 6V sealed lead-calcium, maintenance-free, rechargeable battery

### Electronics

- Low voltage disconnect
- Dual voltage 120/277, 60Hz
- LED indicator light and push-to-test switch
- Automatic solid-state charger recharges battery in 24 hours
- A 2 hour run time in emergency mode
- 5.4W of remote capacity standard

### Approvals

- UL listed for damp location 68°F to 122°F (20°C to 50°C)
- Meets UL 924, NFPA 101 Life safety code, NEC, OSHA, local and state codes
- Meets City of Chicago requirements

### Warranty

- Three-year full warranty (subject to proper installation and maintenance)
- Detailed warranty terms located at: [www.lightalarms.com](http://www.lightalarms.com)



### Ordering format

Series	Lamp
CHB	-2LR= Double Steel Round LED
<b>Example: CHB-2LR</b>	

### Dimensions (Dimensions are approximate and subject to change):

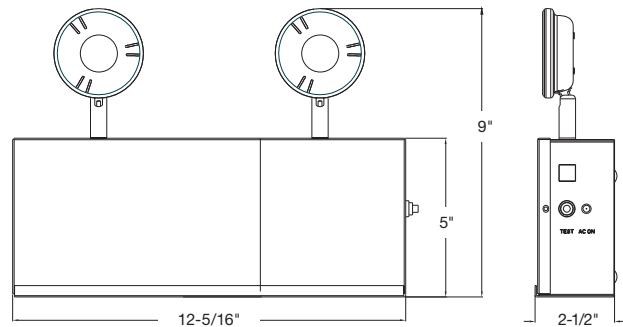

### Power consumption chart

Model	AC specs	DC specs
CHB-2LR	120VAC, 60HZ, 0.08A 8.4W	Lead-calcium Minimum 120 minutes
CHB-2LR	277VAC, 60HZ, 0.04A 9.4W	

<sup>1</sup>Compatible only with ELF612/LED remote. One double dedicated remote.