

Light Support Power Systems 3FTC Three Phase Series

Fast transfer emergency lighting inverter system 4.8KVA – 50KVA



Features

- 98% efficient @ full load
- PWM/IGBT technology
- Self-testing/self-diagnostic
- User programmable with password protection
- Standard input circuit breaker
- Internal maintenance bypass (MBB)
- RS232 communication port
- Microprocessor controlled
- Automatic event and alarm log
- 90 min. standard run time
- Generator compatibility
- Available in Y or Δ input configuration

- Custom voltages available
- Automatic event, test and alarm log
- LCD display
- Reduced footprint (stackable cabinets)
- Maintenance-free VRLA batteries
- Forced air cooling during emergency mode only

UL listed to UL 924. Meets NFPA101, NFPA70, NFPA 110, OSHA, UBC, SBCCI. NYC approved.



Electrical characteristics and dimensions³ (data provided for standard lead-calcium batteries)³

Power rating ¹ kVA=kW	Effic. at full load %	Max. input current (a)		Heat loss in normal mode (BTU/HR)	Batt.			Electronics cabinet			Battery cabinet dimensions ^{1,2}			No. of batt. cab	Batt. cab. weight lbs (empty)	Elec. cab. weight lbs	Batt. system weight lbs	Total system weight lbs
		120V/208V	277V/480V		VDC	A	No. of batt.	W"	H"	D"	W"	H"	D"					
4.8	98	17	7	326	144	39	12	30	47	25	30	47	25	1	N/A	535	888	1633
6	98	21	9	408	180	39	15	30	47	25	30	47	25	1	N/A	535	1110	1855
8	98	28	12	544	240	39	20	30	47	25	30	47	25	1	N/A	535	1480	2247
10	98	35	15	680	144	81	24	30	47	25	30	47	25	1	N/A	639	1776	2835
12.5	98	43	19	850	180	81	30	30	47	25	30	47	25	2	N/A	639	2220	3279
16.7	98	58	25	1136	240	81	40	30	47	25	30	47	25	2	210	639	2960	4063
24	98	84	36	1632	240	117	60	44	72	31	48	72	31	1	232	1250	4440	6390
33	98	115	50	2244	240	160	40	44	72	31	48	72	31	2	420	1250	6080	8630
40	98	139	60	2720	240	194	100	44	72	31	48	72	31	2	420	1450	7400	10150
50	98	174	75	3400	240	243	60	44	72	31	48	72	31	2	464	1460	9120	11980

¹Batteries are installed in the electronics cabinet for 1.5 to 5kVA systems

³Special voltages or batteries may change the size, weight or number of cabinets

²Battery cabinets are stackable. To be installed on top of the electronics cabinet max. 16.7

Ordering format

System type ¹	Battery type	VA/W rating	Input/output voltage	Run time ²	Output breaker config.	Output breaker voltage
1= 120/208 2= 277/480 Other voltages available	SC= Sealed lead-calcium G= 20 year battery warranty	N= 4800 R= 6000 S= 8000 T= 10000 U= 12500 W= 50000	V= 16700 X= 24000 Y= 33000 Z= 40000	3FTC	Blank= 90 minutes 120= 120 minutes	B= Normally-on N= Normally-off A= 120, 1 pole B= 208, 2 pole C= 240, 2 pole D= 277, 1 pole E= 120/208, 3 pole F= 277/480, 3 pole G= 480, 2 pole

¹Special voltages may change the size, weight or number of cabinets

²Other run times available 120 min. not available for 50kVA

Output breaker amp. ³	Output breaker qty.	Options	Monitoring ⁵	Warranty (1 yr. std.)	Accessories
10= 10 16= 16 20= 20 25= 25 32= 32 40= 40 50= 50 63= 63	01-42= Choose the number of output breakers between 01 and 42 ⁴	A= Remote summary alarm panel (requires S option) BTM= Battery temperature monitor BL= Breaker locks C= Status monitoring contacts DT= Drip top F= Fast charge I= Inverter on dry form C contact L= Load control interface M(MBB)= Internal maintenance bypass O= Output transfer delay P= Remote status panel (requires C option) S= Summary fault form C contacts SEA= Serial to ethernet adapter T= Output trip alarm (supervised) V= Time delay 15 minutes Z= Seismic bracing/mounting ZM= Zone monitoring	BAC= Bacnet communication (MSTP) BIP= Bacnet IP MIP= Modbus TCP/IP MOD= Modbus RTU R= Remote meter panel	2YW= Startup and same day training 2YT= Startup, same day training and full run test ⁶ 5YP= 5 year preventative maintenance plan (startup included) 5YW= 5 year extended electronics warranty TR= Training if required on day other than startup	Blank= No accessories EMBP= External maintenance bypass switch ⁷ SPARES= Spare fuses and circuit boards SPAREF= Spare fuse kit

³Higher amp ratings available (contact factory)

⁵May only choose one monitoring option

⁶Load must be connected, additional day on-site required

⁷Cannot be purchased with internal output breaker option

Example: 1SCN3FTCBA1010CBAC

Specifications

GENERAL

Design

Standby. PWM inverter type utilizing IGBT technology with 2ms transfer time.

Control

- Microprocessor controlled, 2 x 20-character display with touch pad controls & functions
- 5 LED indicators & alarm with ring-back feature

Metering

Input & output voltage, battery voltage, battery & output current, output VA, temperature, communications

Communications RS-232 port (DB9)

ELECTRICAL INPUT

Voltage

120/208 or 277/480 3 phase 4-wire +10% - 15%. Contact factory for all other voltages.

Input power walk-in

Limiting inrush current to less than 125%, 10 times for 1 line cycle

Input frequency

- 60Hz, +/-3%, 50Hz available upon request
- Protection input circuit breaker
- Harmonic distortion <10%
- Power factor 0.5 lag/lead

ELECTRICAL OUTPUT

Voltage

120 or 277VAC 1-phase 2-wire. Contact factory for all other voltages.

Static voltage

Load current change +/-4%, battery discharge +/-4%

Dynamic voltage

- +/-3% for +/-25% load step change,
- +/-6% load step change, recovery within 3 cycles
- Harmonic distortion <3% THD for linear load
- Output frequency 60Hz +/- 0.05Hz during emergency mode
- Load power factor 0.5 lag to 0.5 lead
- Overload capability: to 115% continuous rating - 150% for 2.5 seconds, 250% for 3 line cycles
- Protection optional distribution circuit breaker
- Crest factor 2.8

ENVIRONMENTAL CONDITIONS

Storage/transport

- -4°F to 158°F (-20°C to 70°C) without batteries max. 3 months at 104° F (40° C)
- -0°F to 104°F (-18°C to 40°C) with batteries

Operating temperature

System operates safely from 32°F to 104°F (0°C to 40°C) but optimum operation is between 68° F and 86°F (20°C to 30°C). Battery performance can be affected by temperature.

Altitude

<10,000 feet (above sea level) without de-rating

Relative humidity

0 to 95% non-condensing

Audible noise

45 dBA @ 1m from surface in emergency mode

Cabinets - Modular design, freestanding NEMA type 1 steel cabinets powder coated for corrosion and scratch resistance. Front access design through hinged lockable doors requires only 39" front clearance and 12" top clearance. Cabinets are stackable up to 16.7kVA, if required to further reduce the footprint. Top and left side conduit entry with knockouts up to 16.7kVA. Left side only for 24kVA and up.

Inverter - Using IGBT/PWM technology the inverter converts the DC voltage supplied by the batteries to AC voltage of a precise stabilized amplitude and frequency, suitable for most sophisticated electrical equipment. True sinusoidal output waveform with very low distortion (less than 3% for linear loads). Overload capability of up to 150% for 12 line cycles.

Charger - Fully automatic, temperature compensated, microprocessor controlled charger recharges fully discharged batteries in maximum 24 hours at nominal AC input voltage. AC input current limiting and over voltage protection included

Battery - System is provided standard with 10 year, maintenance-free, sealed valve regulated, front terminals lead-calcium batteries. 20 years life sealed lead-calcium battery also available. 90 min. standard discharge time at full load under normal operating temperature. Low voltage disconnect protection included. No special ventilation or filters required.

Supervision - Automatic self-tests consist of a 5-minute monthly and 90-minute annual function. The front-mounted control panel includes 5 LED indicators, a 2-line 20-character LCD display, a keypad to control and monitor the internal operation of the system. This allows the operator to easily "watch" system functions as they occur and check on virtually any aspect of the system's operation. Standard RS232 diagnostic interface.

Alarms - High/low battery charger voltage, high/low AC input voltage, near low battery, low battery, load reduction fault, output overload, high ambient temperature, inverter fault, output fault, optional output circuit breaker trip.

Optional features - Output circuit breakers, output trip alarms, 20 years sealed batteries, 12 hours fast recharge, internal/external maintenance bypass switch (BBM), remote summary alarm panel, summary alarm dry form C contact, inverter on dry contacts, normally-off output, bypass relays, seismic mounting, circuit breaker locks, battery temperature monitor, drip top, output transfer delay, time delay, zone monitoring, serial to ethernet, BACnet MS/TP, BACnet IP, remote meter panel, MODBUS serial, MODBUS TCP/IP, serial to ethernet adapter.

Factory start-up - Includes one additional year of warranty. See warranty conditions.

Warranty Limited manufacturer warranty is one year, parts and labor, for system electronics or two year with factory start-up program. Battery warranty is one year full plus 9 years pro-rata for a total of 10 years, under normal operating conditions. System must be put in service within 6 months from ship date in order to validate warranty. Consult factory for other type batteries than the standard one.

Detailed warranty terms located on page 197 or online at: www.lightalarms.com

Single line diagram

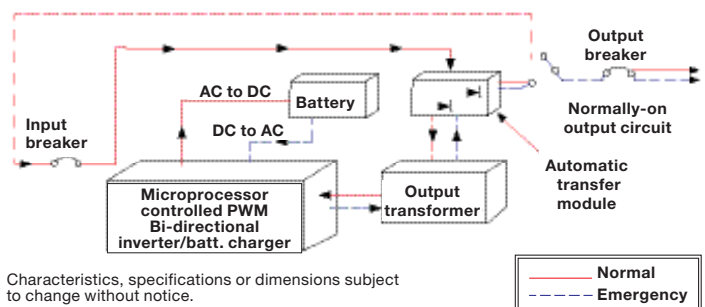

Characteristics, specifications or dimensions subject to change without notice.