



SEVERE XV COMBO UNIT

TYPE: _____
 CATALOGUE #: _____
 NOTES: _____



**Sealed, Maintenance-free
 Nickel-Cadmium battery
 UL listed for wet, damp
 and cold locations.**

Listed to UL924 Standard



NEMA-4X



Application

The Severe XV Combo Unit is designed and engineered with style in mind and sets new standards for emergency lighting in today's toughest environments. Whether it is a large warehouse, heavy-duty plant or food processing installation, the Severe XV Combo unit is the solution for all your industrial emergency lighting. Its tamper-proof revolutionary compact design (Patent pending) makes it also suitable for commercial applications as well as for schools or public facilities. This Combo unit includes, in a slim one-piece enclosure, a battery unit, an exit sign and two emergency light heads. The Exit sign is available in single or double-face configurations. High-efficiency LED's evenly illuminates the exit signage. The innovative, fully adjustable emergency heads is an industry first and offers the option of standard MR16 halogen lamps or MR16 white LED lamps. The unit great versatility allows for end, ceiling or wall-mount installation.

Features

- **RELIABILITY:** The Severe XV Series Combo unit carries a 3-year limited warranty.
- **HOUSING:** The Severe XV Series Combo NEMA-4X rated housing can withstand moisture, dust and corrosion. The faceplates are molded of heavy-duty vandal-resistant polycarbonate and the rugged UV-stabilized thermoplastic body will not dent, peel or corrode. The unit is equipped with stainless steel tamper-proof screws. A special bit is provided with every unit and additional bits can be ordered separately (see accessories). The unit comes in a choice of three colors: mist white, black or gray. The unit is NSF Certified for use in food processing plants.
- **MOUNTING:** The unit comes standard with a universal mount canopy kit allowing end, ceiling or wall-mount installation. A universal knockout pattern allows direct mounting on junction box. Knockouts are also available for conduit entry and are located on the top and both sides of the unit.
- **LIGHT SOURCE:**
 - High-efficiency LED's, evenly illuminate the legend of the Exit sign.
 - The fully field adjustable emergency lighting heads can be equipped

with standard MR16 halogen lamps or MR16 white LED lamps (lamp consumes 5 Watts and uses 3 watts of white LED).

- **CHARGER:** The Severe XV Series Combo unit is equipped with the fully automatic Lightalarms Integrated Diagnostic micro-controller board. The micro-controller tests, detects and indicates battery, charger circuitry, lamps or LED strip failures. An external LED signals a general service alarm while an internal diagnostic LED display indicates the nature of failure. The board is factory preset to non-audible diagnostic and a 15 minutes time delay. These functions can be enabled or disabled during installation. The equipment comes standard with a dual voltage input of 120/277 Vac.

Battery

Unit comes with a sealed, maintenance-free Nickel-Cadmium battery with a capacity of 6V, 12W or 12V, 24W for 90 minutes of emergency operation. It is suitable for wet and damp locations (10°C to 40°C) (50°F to 104°F).

Options

(Add Suffix to Model No.)	Suffix
Double face	
Exit sign unit (order 0 heads) featuring remote capacity of 12 or 24W	
Cold weather location (-40°C to +25°C) (-40°F to +77°F)	CW4
(6V-12W, single face only)	
Fire alarm activated flasher	FA
Flasher/Buzzer (AC power failure)	F/B
Flasher (AC power failure)	FL

Accessories

(Order as separate item)	Model
Additional special bit for tamper-proof screw	TPB

Electrical Power Consumption:

Unit	AC specification		
	Voltage	Current (Max.)	Power (Max.)
XV12N	120 / 277 Vac, 60 Hz	0.12 / 0.06 A	Less than 13 W
XV24N	120 / 277 Vac, 60 Hz	0.18 / 0.08 A	Less than 20 W
Cold Weather option	120 / 277 Vac, 60 Hz	0.20 / 0.09 A	Less than 24 W

Specifications For Severe XV Combo Unit

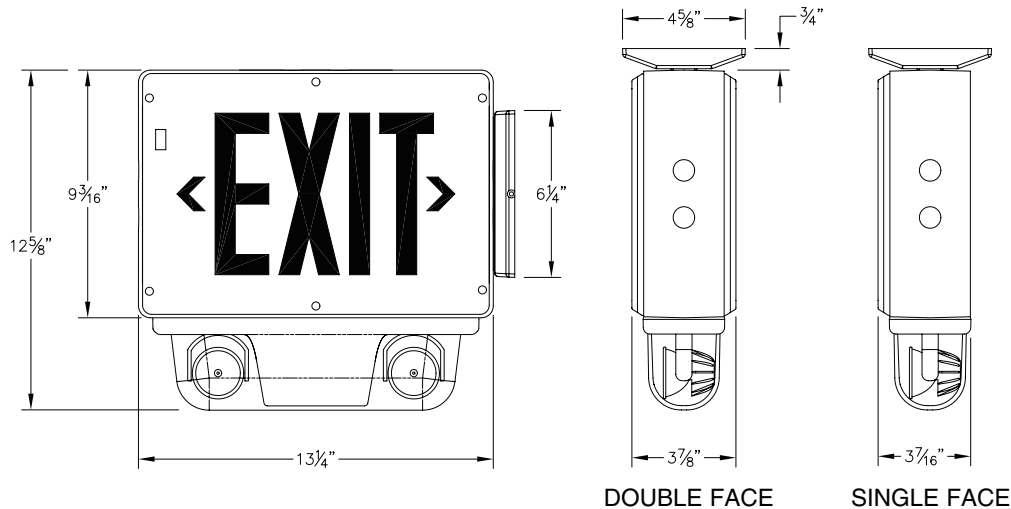

Supply and install Lightalarms **Severe XV Series Combo unit** with electrically compatible fixtures or exit signs as indicated on the plans.

The combination unit shall be able to provide exit signage and the emergency lighting with its entire electronics and power source in a slim one-piece compact sealed NEMA 4X-rated housing.

The emergency lighting MR16 heads shall be located at the bottom of the unit and covered by a sealed clear lens made of UV-stabilized polycarbonate. These emergency lighting heads shall be equipped with an innovative swivel system allowing for up to a 180° rotation in order to provide for an illumination in any direction of the path of egress.

The unit shall be NEMA-4X-rated and designed specifically for high abuse areas, wet and damp locations, as well as for cold weather applications (CW4 option). The exit signage faceplate(s) shall be constructed of heavy-duty vandal-resistant polycarbonate and features an even illuminated legend. The legend light source shall be composed of high efficiency light emitting diodes (LED).

The Lightalarms Improved Diagnostic Micro-controller board shall supply the rated load for a minimum of 90 minutes to 87.5% of the rated battery voltage. The unit shall be rated 120/277Vac, 60Hz and be UL listed. The unit shall have a remote output of ___ V ___ W.

The charger shall at first continuously recharge the battery then, when the battery is at full capacity, the charger will periodically pulse charge the battery in stand-by mode. This pulse-type charger promotes long battery life and reduces the potential for grid corrosions. Its charge voltage is factory set to +/-1% tolerance and is temperature compensated. The charger incorporates Lockout and Brownout Circuits, and Low Voltage Disconnect. It protects the unit from over-current, short-circuit, and reverse polarity.

This unit shall self-test for 1 minute every 30 days, 30 minutes on the 6th month and 90 minutes every 12 months. The unit shall be capable of full recharge in compliance with UL specifications. The unit shall be supplied with a magnetic test switch. A "Service-Required" lamp shall be located near the test switch and flash when a fault is detected. A LED-based diagnostic display shall be located inside the equipment and shall identify the source of failure (battery, charger, circuitry, or lamps).

The unit shall be Lightalarms Model - _____

*Unit Warranty

Entire unit (excluding lamps) carries a 3-year full warranty

*Battery Warranty

Nickel-Cadmium batteries carry a 5-year full warranty and a 5-year pro-rata warranty.

*Subject to proper installation and maintenance.

Ordering Information

Example: **WWXV12E1RD4X2M6CW4**

Housing/Face Color	Series	Capacity	Faces	Letter Color	Diagnostics	Housing *	# of Heads	Lamp/Wattage	Option
Blank= black/black	XV	12E= 6V-12W	1= single face	R= red letters	D= improved diagnostics non-audible(standard)	4X= NEMA-4X	0= 0 heads*	M6= MR16, 6V-6W	Blank= no options *CW4= cold weather
BW= black/white		24E= 12V-24W	2= double face	G= green letters			2= two heads	M12= MR16, 12V-12W	
BA= black/aluminum					* Remote Lamp(s) must be connected		L5= LED, 12V-5W		
WW= white/white					DA= improved diagnostics - audible			*Available in 12E1 version only	
WB= white/black									
WA= white/aluminum									
GA= gray/aluminum									
GW= gray/white									
GB= gray/black									

