



SERIES LCA-2MRS

TYPE: _____
 CATALOGUE #: _____
 NOTES: _____



6 Volt Thermoplastic Battery Unit
Damp Location Listing is standard on all models
Sealed Maintenance-Free Lead Calcium Battery
UL Listed

New Improved Look



The LCA-2MRS Series, is the perfect battery unit for use where style and design

Features

- **Reliability**
The LCA-2MRS Series has a three-year full warranty (excluding lamps and fuses).
- **Unit Data**
The unit is completely self-contained and the housing is constructed of high impact, UL recognized, 94, 5VA thermoplastic. The compact design will allow for space restrictions often encountered. The snap together housing facilitates mounting in any orientation.

- **Lamps**
Furnished with two 6 volt, MR16 glare free halogen lamp heads

- **Charger**
 - Automatic, temperature compensated, charger.
 - High capacity, automatic, dust-tight instantaneous transfer relay.
 - Low voltage disconnect prevents over discharge of battery. Automatic brownout protection is provided.
 - Labor saving AC line latch prevents battery discharge during installation to a non-energized circuit.

Accessories

- (Order as a separate item)
- Replacement MR16 Lamp 580.0072
 - Wire Guard WG13

Dimensions And Selection Chart

Dimensions are approximate and subject to change.

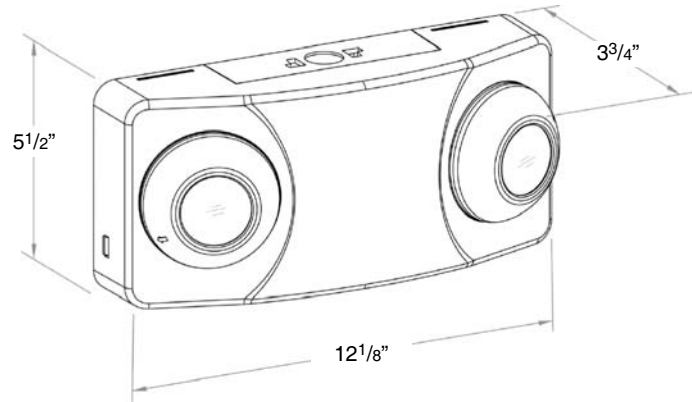

Ordering Information

Example: LCA-2MRSB

Series	Light Heads	Colors
LCA = series	6V 5W MR16 Halogen	B = black



Thomas & Betts