



SERIES FG, F12G

TYPE: _____
 CATALOGUE #: _____
 NOTES: _____



Listed to UL924 Standards

Weather and Corrosion-Resistant Emergency Lighting Units 6 & 12 Volt Maintenance-Free Lead Calcium & Nickel-Cadmium Battery



Application

Designed for industrial applications, especially for installations in a corrosive atmosphere.

Features

- **HOUSING:** Molded gray high impact thermoplastic case features oil, water and dust-tight construction, stainless steel hardware, single piece neoprene gasket and vented battery compartment.
- **MOUNTING:** External mounting feet are provided. Conduit entry can be made with a punch, drill or hole saw.
- **ELECTRONICS:**
 - Automatic, temperature compensated, pulse type charger.
 - High capacity, automatic, dust-tight instantaneous transfer relay.
 - Low voltage disconnect prevents overdischarge of battery. Automatic brown out protection is provided.
 - Labor saving AC line latch prevents battery discharge during installation to a non-energized circuit.
 - Self-testing in accordance with NFPA 101, Life Safety Code. Unit tests itself every thirty days for one minute, thirty minutes on the sixth month and ninety minutes annually.

- **CONTROLS:**
 - Charger monitor LED indicates state of charge of the battery.
 - AC-ON LED indicates AC power is on.
 - Momentary test switch allows for quick operational check of entire system.

- **POWER REQUIREMENTS:**
 120/277 Volt AC, 60Hz, 0.3/0.15 Amp

Battery

6 or 12 volt long life, maintenance-free sealed lead calcium or Nickel-Cadmium battery.

Options

(Add Suffix to Model No.)	Suffix
Voltmeter	-V*
Ammeter	-A*
Improved Diagnostics	-ID
Improved Diagnostics (non-audible)	-IDNA
Time Delay (12 min.)	-TD**
Thermal Jacket 120V	-H1
Thermal Jacket 277V	-H2
Lamp Disconnect Switch	-DS
3-wire Cord & Plug (120V)	-3CP
3-wire Cord & Plug (277V)	-3CP-277
Phototest Switch	-PTS

**Not required with ID-IDNA option.
 *Choose either a Voltmeter or a Ammeter.
 Note: Certain option combinations may affect the listing. Please contact the factory for specifics.

Lamp Heads

Standard size, high impact, resistant thermoplastic heads, furnished with PAR36 sealed beam lamps.

Accessories

(Order as separate item)	Model
Wire Guard.....	WG3-L

Unit Selection Chart:

Each unit furnished with two 25W High Intensity incandescent lamp.

Volts	Model No. (unit/Lamp Suffix)	Battery Type	Capacity in Watts to 87 1/2 % of Nominal Battery Voltage			
			1 1/2 Hrs.	2 Hrs.	3 Hrs.	4 Hrs.
6	2FG1/4510	Sealed Maintenance-Free Lead-Calcium	50	36	25	18
	2FG2/4510		100	75	50	36
12	2F12G1/4446		50	36	25	18
	2F12G2/4446		100	75	50	36
24	2F12N1/4446	Nickel-Cadmium	50	36	25	18
	2F24N2/L28		100	75	50	36

Specifications For Series FG, F12G

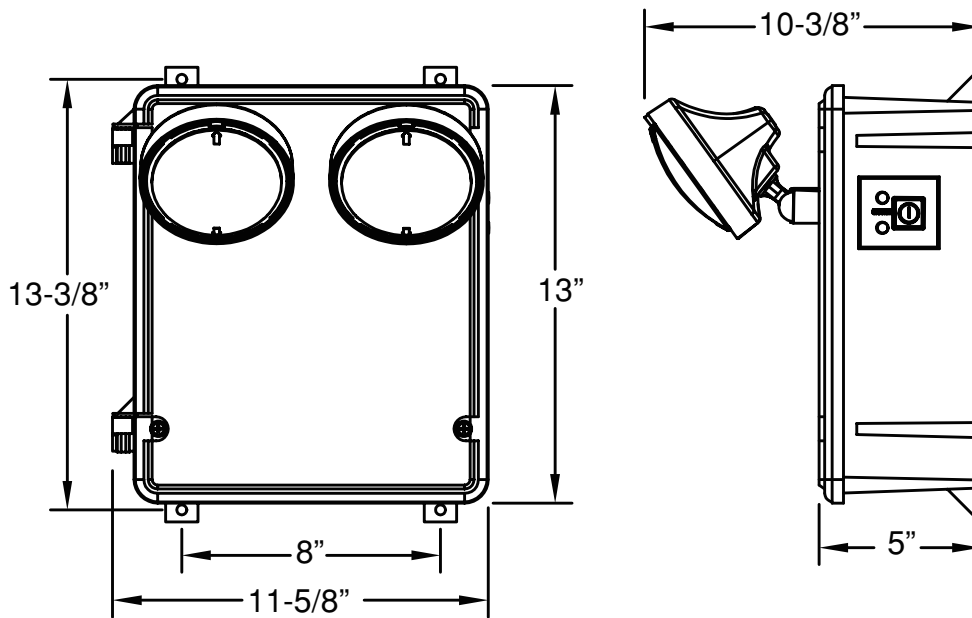

GENERAL: The contractor shall furnish and install emergency lighting equipment that is weather and corrosion resistant consisting of 6 or 12 volt battery units. Input power shall be 120/277Vac, 60 Hz.

HOUSING: The battery and all components shall be housed in a molded high impact thermoplastic enclosure, in gray color, corrosion resistant and be of oil, water and dust-tight construction. Unit shall have vented battery compartment, external mounting feet and back panel for mounting of components.

LAMP HEADS: The unit shall be provided with one or two standard lamp assemblies, mounted to front of the unit case, molded of high impact thermoplastic material. The heads shall be fully adjustable horizontally and vertically without tools.

BATTERY: Unit shall contain a 6 or 12 volt sealed, maintenance-free Lead Calcium or Nickel-Cadmium battery. Capacity shall be as shown in Unit Selection Chart.

TRANSFER: The sealed dust-tight transfer relay shall automatically and instantaneously connect the DC lamp load to the battery upon failure of the normal AC supply, and shall disconnect the lamps when normal power is restored.

CHARGER ASSEMBLY: An automatic, temperature compensated, pulse type charger shall be provided. The charger shall be reverse polarity protected, short circuit proof and capable of recharging the battery in accordance with UL924.

A low voltage disconnect shall be provided to shut down lamp load and circuitry when battery reaches 87½% discharge to protect battery from deep discharge damage. **Brownout circuit** shall be provided which activates emergency mode when AC power dips below 80-85% of nominal voltage. **AC line latch** circuit shall be provided which prevents battery discharge during installation to a non-energized circuit.

CONTROLS: **AC-ON LED** shall be provided to indicate the presence of AC power to the unit. **Charger monitor LED** shall be provided to indicate state of charge of the battery. **Momentary test switch** shall be provided to allow for periodic testing of the entire system.

WARRANTY: Entire unit (less lamps and fuses) shall carry a 3 year full warranty against defects in parts or workmanship under normal and proper use. The sealed Lead Calcium battery shall carry an additional 3 year pro-rata warranty.

The sealed Nickel-Cadmium battery will carry a 5 year full warranty with an additional 5 year pro-rata warranty.

MANUFACTURER:

Unit shall be **Lightalarms** Model _____

Ordering Information

Example: 2FG1/4510-V

Number of Heads	Series	Capacity Indicator	Lamp Option	Option
2 = 2 heads	FG = series	1 = capacity	/4510 = lamp option <small>*See lamp data sheet for other lamp wattages.</small>	-V = voltmeter

