



SERIES ECN, E12CN, ENN, E12NN

TYPE: _____
 CATALOGUE #: _____
 NOTES: _____



NEMA 6 & 12 Volt Industrial Emergency Lighting Units

Enclosure meets requirements for operation under NEMA1, 2, 3, 3R, 3S, 4, 4X, 12 and 13 conditions.



Application ENN and ECN (6 volt) and E12NN and E12CN (12 volt) NEMA series industrial emergency lighting units are designed for use in hostile environments where the presence of water, fibers, dirt, dust, and corrosive gases can be potentially damaging to internal components.

Features

- **CONSTRUCTION:** All units are housed in water, corrosion-resistant cabinets constructed from glass-reinforced structural foam. Cabinets are silicone sealed and/or gasketed around all entryways, push-to-test switch is completely enclosed and corrosion resistant bushing is provided for field installed conduit entry. Breather devices allow for ventilation of battery gases without admitting damaging elements. All external hardware is stainless steel. A unique door-hinging device allows for removal of door panel or retention of the hinge by means of a small field adjustment.
- **ADVANCE ELECTRONICS:**

 - Automatic solid state charger.
 - Low voltage disconnect - protects batteries against excessive discharge.
 - Brownout protection circuit. (Series ECN and E12CN.)
 - Dual input voltage 120V/277V 60Hz, 0.3/0.15A.
 - Load relay with fused distribution circuit.
- **CONTROLS:**

 - Enclosed momentary test switch.
 - AC-ON indicator light.

Battery

Series ENN and E12NN units feature a 6 or 12 volt sealed, maintenance-free rechargeable Nickel-Cadmium battery. The NiCad battery features long life and superior resistance to temperature extremes. Series ECN and E12CN units feature a 6 or 12 volt maintenance-free sealed Lead Calcium battery.

Lamp Heads

Units are equipped with a choice of halogen or incandescent sealed beam lamps. See lamp chart. Lamps are housed in industrial gray thermoplastic shells with matching swivels. Lamp housings are rain-tight and corrosion resistant. Wire connections are silicone sealed.

Unit Selection Chart

Volts	Unit Model No.	Battery Type	Input Watts	Capacity in Watts to 87 1/2 % of Nominal Battery Voltage			
				1 1/2 Hrs.	2 Hrs.	3 Hrs.	4 Hrs.
6	2ECN25	Sealed Lead	18	25	20	15	12
	2ECN50	Lead	18	50	40	30	22
	2ECN100	Calcium	40	100	75	50	36
	2ENN25	Sealed Nickel-Cadmium	18	25	20	15	12
12	2ENN50	Nickel-Cadmium	18	50	40	28	22
	2E12CN50	Sealed Lead Calcium	18	50	40	30	22
	2E12NN50	Sealed Nickel-Calcium	18	50	40	28	22

Options

(Add Suffix to Model No.)	Suffix
Time Delay (12 min.)-TD
Voltmeter-V
Ammeter-A
Disconnect Switch-DS
Thermal Jacket 120V-H1
Thermal Jacket 277V-H2

Accessories

(Order as separate item)	Model
GuardWG3-L
Cord & Plug Kit (120V)WP-3CP
Cord & Plug Kit (277V)WP-3CP-277

Specifications For Series ECN, E12CN, ENN, E12NN

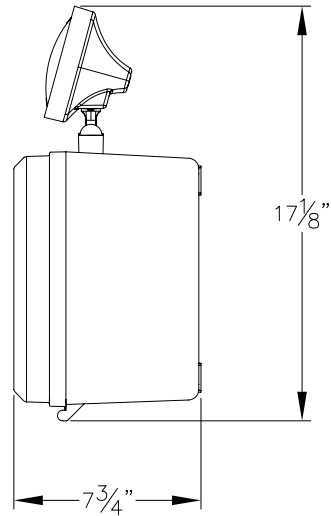
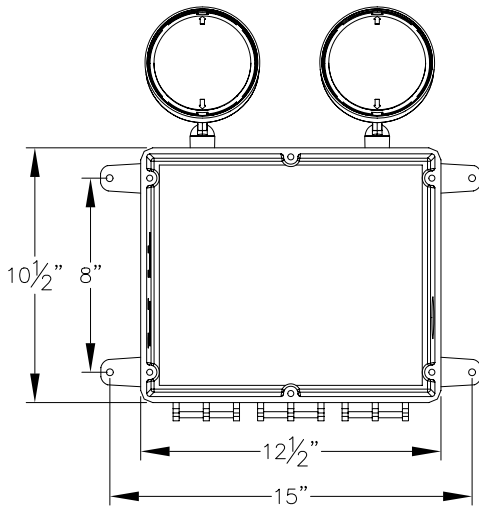

GENERAL: The contractor shall furnish and install as indicated on all plans a 6 or 12V emergency lighting unit designed to meet requirements for NEMA 1, 2, 3, 3R, 3S, 4, 4X, 12 and 13 classifications. Installation to be in accord with Article 700 of the National Electrical Code.

CABINET: Shall be injection-molded, glass-reinforced structural foam, industrial gray in color. All entryways shall be fully gasketed and silicone sealed. All external screws to be stainless steel. Cabinet venting to be by rain-tight breather devices.

LAMP HEADS: Sealed beam lamps of _____ volt _____ watts halogen type (8 watts only) or incandescent (18 or 25 watts) as required. Lamps to be housed in rain-tight, thermoplastic housing with matching swivels. Wire connections to lamps shall be silicone sealed.

STANDARD CONTROLS: All units shall be equipped with an enclosed sealed momentary test switch which simulates a power failure and tests the entire system, an AC indicator light, DC load relay, fused distribution load circuit and a low voltage disconnect. Unit shall include a dual voltage 120/277Vac transformer.

BATTERIES: Series ENN and E12NN units shall contain sealed, maintenance-free, 6 or 12 volt Nickel-Cadmium batteries. Series ECN and E12CN units shall contain sealed, maintenance-free, 6 or 12 volt Lead Calcium batteries.

CHARGER: (Both battery types) shall be completely automatic, feature solid state components and be capable of recharging the batteries in accord with the provisions of UL 924. Charger shall provide a high charge rate immediately upon restoration of AC power and a float rate to maintain the battery at float voltages. For sealed Nickel-Cadmium batteries (Series ENN and E12NN) charger shall be of a constant current type.

For Sealed Lead Calcium Batteries (Series ECN and E12CN) charger shall be of a pulse type.

LIMITED WARRANTY: The entire unit (less lamps and fuses) shall carry full three (3) year warranty against defects in parts and improper workmanship under normal operation. Sealed Nickel-Cadmium batteries shall carry an additional five (5) year pro-rata warranty.

Sealed Lead Calcium batteries shall carry an additional three (3) year pro-rata warranty

MANUFACTURER:

Unit shall be **Ligtalarms** Model _____

Ordering Information

Example: 2ECN100/H7551-V

Number of Heads	Series	Capacity Indicator	Lamp Option	Options
2 = 2 heads	ECN = series	100 = capacity	/H7551 = 6V 8W halogen <small>*See lamp data sheet for other lamp wattages.</small>	-V = voltmeter



Thomas & Betts