



RD-CH SERIES

Recessed Steel Housing
Lead-Calcium battery



FEATURES

Housing

- 20 gauge steel housing designed for easy access to internal components
- Corrosion-resistant baked enamel mist white finish standard, black optional
- Provision for mounting up to 2 lighting heads

Mounting

- Ceiling or Wall Mount; Mounting Brackets included for lay-in installation in T-Bar grid ceiling as well as dry wall

Electronics

- Automatic, temperature-compensated, pulse-type charger
- High capacity, automatic, dust-tight instantaneous transfer relay
- Low voltage disconnect prevents over discharge of battery
- Automatic brownout protection is provided
- Battery lock-out prevents battery discharge during installation
- Fused output circuit

Improved Diagnostics option

- Units equipped with Improved Diagnostics shall self-test, by simulating a power failure, in accordance with NFPA101, Life Safety Code one minute monthly, 30 minutes every six months and 90 minutes annually. For complete information refer to page 8.

Controls

- Red charger monitor LED indicates charging of the battery
- Amber AC-ON LED indicates AC power is on
- Momentary test switch allows for quick operational check of entire system

Sealed Maintenance-Free Battery

- 12V Lead-Calcium battery

Approvals

- UL 924 Standard
- Meets City of Chicago requirements

Warranty (subject to proper installation and maintenance)

- Unit has a three year full warranty (excluding lamps and fuses)
- Lead-Calcium battery has a three year full, plus three year pro-rata warranty

ACCESSORIES (Order as a separate item)

Wire Guard (DR1130 heads)	WG6-L
Remote Test Switch (Metal Faceplate)	PSW
Remote Test Switch (Plastic Faceplate)	PSW1

SPECIFICATIONS

Supply and install **Lightalarms® RD-CH Series**.

The emergency lighting unit shall be a self-contained fixture including a sealed maintenance-free Lead-Calcium battery 12V-36W as specified on the unit rating chart. The unit shall supply the rated wattage load for a minimum of 90 minutes to 87-1/2% of rated battery voltage. The unit shall be rated 120/277VAC, 60Hz and be UL924 listed.

The unit charger shall utilize an integrated circuit which samples the battery in relation to temperature, state of charge and input voltage fluctuations. The charger shall be current limited, temperature compensated, short-circuit protected and reverse polarity protected. The unit shall be furnished with an electronic lockout circuit which will connect the battery when the AC circuit is activated, and an electronic brownout circuit which will activate the unit when utility power dips below 80-85% of nominal voltage. A low voltage battery protection circuit shall be provided and will disconnect the load and circuitry from the battery when it reaches 87-1/2% of its nominal voltage. The unit shall be capable of full recharge in compliance with UL924 specifications. The unit shall be furnished with sealed dust-tight relay, a test switch and dual diagnostic LED indicator lights (hi-charge and AC pilot). The cabinet shall be 20 gauge steel designed with mounting brackets included for lay-in installation in T-Bar grid ceiling as well as sheet rock. Unit has provision for mounting up to 2 heads on cabinet.

Units specified with Improved Diagnostics (audible or non-audible) will continuously monitor every critical function of the unit, attached remote lighting heads and/or attached AC/DC Exit Signs. Operational status of the battery, charger and lamps are indicated by individual LED status indicators. Once a malfunction is detected, if audible, a high-pitch audible alarm will sound, and the appropriate LED status indicator will illuminate alerting of the unit malfunction. If non-audible, only the LED status indicator will illuminate alerting of the unit malfunction. The microcontroller shall automatically self-test, by simulating a power failure, in accordance with NFPA101 Life Safety Code for one minute monthly, 30 minutes every six months and 90 minutes annually

Every **RD-CH Series** unit shall be fully warranted for three years, subject to proper installation and maintenance.

Unit shall be **Lightalarms®** catalog number _____.



TYPE _____

CATALOG # _____

NOTES _____

Designed for fully recessed installation
in walls or ceilings



DIMENSIONS

Dimensions are approximate and subject to change.

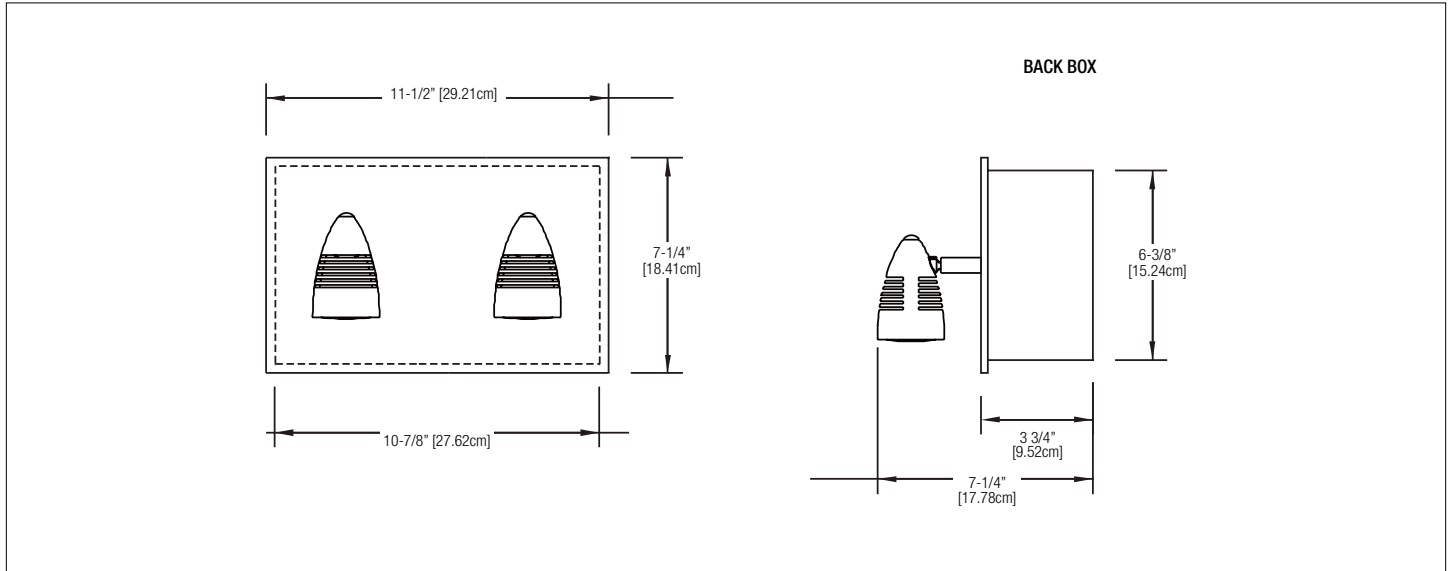

POWER CONSUMPTION / UNIT RATING CHART

SERIES	DC SPECS						AC SPECS	
	BATTERY TYPE	DC VOLTAGE	87.5% BATTERY CAPACITY (IN WATTS) ¹				UNITS DUAL VOLTAGE ²	CURRENT
			90 MIN.	2 HRS.	3 HRS.	4 HRS.		
RD12M3	Lead-Calcium	12	36	25	20	14	120VAC / 277VAC	0.3A / 0.15A

¹ National Electrical Code Specification

² All units 120/277 dual voltage, information based on wiring to specific voltage type

ORDERING FORMAT

# OF HEADS	SERIES/CAPACITY	SERIES	HEAD STYLE	LAMP TYPE	OPTIONS
0= No heads 1= One head 2= Two heads	Lead-Calcium Battery RD12M3= 12V-36W	CH= City of Chicago	/D1= DR1130 (MR16, Metal)	LD7= 12V-4W, MR16 LED LD9= 12V-5W, MR16 LED LD10= 12V-6W, MR16 LED	Blank= Mist White housing, No Options -B= Black Housing -ID= Improved Diagnostics (audible)

EXAMPLE: 2RD6M2/LHK