

## Light Support Power Systems 3FTC Three Phase Series

Fast transfer emergency lighting inverter system 4.8KVA – 50KVA



### Features

- 98% efficient @ full load
- PWM/IGBT technology
- Self-testing/Self-diagnostic
- User programmable with password protection
- Standard input circuit breaker
- Standard internal bypass switch
- RS232 communication port
- Micro-processor controlled
- Automatic event and alarm log
- 90 min. standard run time
- Generator compatibility
- Available in Y or Δ input configuration
- Custom voltages available
- Automatic event, test and alarm log
- LCD display
- Reduced footprint (stackable cabinets)
- Maintenance free standard batteries
- Forced air cooling during emergency mode only



Electrical characteristics and dimensions<sup>4</sup> (data provided for standard lead calcium batteries)<sup>1,4</sup>

Power rating <sup>1</sup> kVA=kW	Effic. at full load %	Max. input current (a)		Heat loss in normal mode (BTU/HR)	Batt. VDC	Batt. A	No. of batt.	UPS cabinet			Battery cabinet dimensions <sup>2,3</sup>			No. of batt. cab	Batt. cab. weight lbs (empty)	UPS cab. weight lbs	Batt. system		Total weight lbs
		120V/208V	277V/480V					W"	H"	D"	W"	H"	D"				weight lbs	weight lbs	
4.8	98	17	7	326	144	39	12	30	47	25	30	47	25	1	N/A	535	888	1633	
6	98	21	9	408	180	39	15	30	47	25	30	47	25	1	N/A	535	1110	1855	
8	98	28	12	544	240	39	20	30	47	25	30	47	25	1	N/A	535	1480	2247	
10	98	35	15	680	144	81	24	30	47	25	30	47	25	1	N/A	639	1776	2835	
12.5	98	43	19	850	180	81	30	30	47	25	30	47	25	2	N/A	639	2220	3279	
16.7	98	58	25	1136	240	81	40	30	47	25	30	47	25	2	210	639	2960	4063	
24	98	84	36	1632	240	117	60	30	72	31	48	72	31	1	232	1250	4440	6390	
33	98	115	50	2244	240	160	40	30	72	31	48	72	31	2	420	1250	6080	8630	
40	98	139	60	2720	240	194	100	30	72	31	48	72	31	2	420	1250	7400	10150	
50	98	174	75	3400	240	243	60	30	72	31	48	72	31	2	464	1250	9120	11980	

<sup>1</sup> Consult factory for 20 year type batteries

<sup>2</sup> Batteries are installed in the electronics cabinet for 1.5 to 5KVA systems

<sup>3</sup> Battery cabinets are stackable. To be installed on the right side of the electronics cabinet.

<sup>4</sup> Special voltages or batteries may change the size, weight or number of cabinets

### Ordering format

System type	Battery type	Input voltage <sup>3</sup>	VA/W rating	Output voltage <sup>3</sup>	Run time <sup>2</sup>	Input breaker	RS232 port	Internal Bypass Switch	Output breakers <sup>4</sup>	Options <sup>1</sup>
<b>3FTC</b>	<b>SC=</b> Sealed Lead- Calcium	<b>120/208</b> <b>277/480</b>	<b>N-</b> 4800 <b>R-</b> 6000 <b>S-</b> 8000 <b>T-</b> 10000 <b>U-</b> 125000 <b>V-</b> 167000 <b>X-</b> 24000 <b>Z-</b> 40000 <b>W-</b> 50000	<b>120/208</b> <b>277/480</b>	<b>90</b>	<b>ICB</b>	<b>RS232</b>	<b>MBYP</b>	<b>OCBxxx-</b> No trip alarm  <b>OCAxxx-</b> With trip alarm	<b>20Y-</b> 20 yr sealed batteries <b>12HR-</b> 12 hr fast recharge <b>NOFF-</b> Normally Off output 1PH <sup>6</sup> <b>EMBP-</b> External bypass switch <sup>5</sup> <b>RMP-</b> Remote metering panel <b>RSAP-</b> Remote summary alarm panel <b>DCS-</b> Dry summary alarm contacts <b>INVON-</b> Inverter on dry contacts <b>NOFF3-</b> Normally OFF output 3PH <sup>3</sup> <b>MOD-</b> External modem <b>FAX-</b> Fax modem <b>BPR-</b> Bypass relays <b>BATM-</b> Battery cycle warranty monitor
										<b>MOD-</b> External modem <b>FAX-</b> Fax modem <b>BPR-</b> Bypass relays <b>SEIS-</b> Seismic mounting <b>ZONEM-</b> Zone monitoring

**Example: 3FTC-SC277/480V277/480-90-ICB-RS232-MBYP-OCB1220-DCS-20Y**

<sup>1</sup> See page 169 for options description. Summary alarm dry contacts and seismic brackets are standard

<sup>2</sup> Other run times available

<sup>3</sup> 1PH are input voltages available for 1 phase systems. 2PH are input voltages available for 3 phase systems.

<sup>4</sup> Max. 14 unsupervised single pole positions or 8 with trip alarm. See page 169 for output breakers option details.

<sup>5</sup> Not available in 3 Phase version

<sup>6</sup> Normally Off loads cannot exceed 20% of total KVA rating with any combination of H.I.D loads

**Specifications**

**GENERAL**

**Design**

Stand-by. PWM inverter type utilizing IGBT technology with 2ms transfer time.

**Control**

- Microprocessor controlled , 2 x 20-character display with touch pad controls & functions
- 5 LED indicators & alarm with ring-back feature

**Metering**

Input & Output Voltage, Battery Voltage, Battery & Output Current, Output VA, temperature, communications

**Communications** RS-232 port (DB9)

**ELECTRICAL INPUT**

**Voltage**

120/208 or 277/480 3 phase 4-wire +10% - 15%. Contact factory for all other voltages.

**Input Power Walk-In**

Limiting inrush current to less than 125%, 10 times for 1 line cycle

**Input Frequency**

- 60Hz, +/-3%, 50Hz available upon request
- Protection Input Circuit Breaker
- Harmonic Distortion <10%
- Power Factor 0.5 lag/lead

**ELECTRICAL OUTPUT**

**Voltage**

120 or 277VAC 1-phase 2-wire. Contact factory for all other voltages.

**Static Voltage**

Load current change +/-4%, battery discharge +/-4%

**Dynamic Voltage**

- +/-3% for +/-25% load step change,
- +/-6% load step change, recovery within 3 cycles
- Harmonic Distortion <3% THD for linear load
- Output Frequency 60Hz +/- 0.05Hz during emergency mode
- Load Power Factor 0.5 lag to 0.5 lead
- Inverter Overload 115% for 5 minutes
- Protection Optional Distribution Circuit Breaker
- Crest Factor 2.8

**ENVIRONMENTAL CONDITIONS**

**Storage/Transport**

- -4°F to 158°F (-20°C to 70°C) without batteries (max. 3 months at 104° F (40° C)
- -0°F to 104°F (-18°C to 40°C) with batteries

**Operating temperature**

System operates safely from 32°F to 104°F (0°C to 40°C) but optimum operation is between 68° F and 86°F (20°C to 30°C). Battery performance can be affected by temperature.

**Altitude**

<10,000 feet (above sea level) without de-rating

**Relative Humidity**

0 to 95% non-condensing

**Audible noise**

45 dBA @ 1m from surface in emergency mode

**Cabinets** - Modular design, freestanding NEMA type 1 steel cabinets powder coated for corrosion and scratch resistance. Front access design through hinged lockable doors requires only 39" front clearance and 12" top clearance. Cabinets are stackable up to 16.7kVA, if required to further reduce the footprint. Top and left side conduit entry with knockouts up to 16.7kVA. Left side only for 24kVA and up.

**Inverter** - Using IGBT/PWM technology the inverter converts the DC voltage supplied by the batteries to AC voltage of a precise stabilized amplitude and frequency, suitable for most sophisticated electrical equipment. True sinusoidal output waveform with very low distortion (less than 3% for linear loads). Overload capability of up to 150% for 12 line cycles.

**Charger** - Fully automatic, temperature compensated, microprocessor controlled charger recharges fully discharged batteries in maximum 24 hours at nominal AC input voltage. AC input current limiting and over-voltage protection included

**Battery** - System is provided standard with 10 year, maintenance free, sealed valve regulated, front terminals lead calcium batteries. 20 years life sealed lead calcium battery also available. 90 min. standard discharge time at full load under normal operating temperature. Low Voltage Disconnect protection included. No special ventilation or filters required.

**Supervision** - Automatic self tests consist of a 5-minute monthly and 90-minute annual function. The front-mounted control panel includes 5 LED indicators, a 2-line 20-character LCD display, a keypad to control and monitor the internal operation of the system. This allows the operator to easily "watch" system functions as they occur and check on virtually any aspect of the system's operation. Standard RS232 diagnostic interface

**Alarms** - High/Low Battery Charger Voltage, High/Low AC Input Voltage, Near Low Battery, Low Battery, Load Reduction Fault, Output Overload, High Ambient Temperature, Inverter Fault, Output Fault, Optional Output Circuit Breaker Trip.

**Optional features** - Output Circuit Breakers, Output Trip Alarms, 20 Years Sealed Batteries, 12 Hours Fast Recharge, External Maintenance Bypass Switch, Remote Meter Panel, Remote Summary Alarm Panel, Summary Alarm Dry Form C Contact, Inverter on Dry Contacts, Normally OFF output, Fax/Modem, Bypass Relays, Auto Dialer, Seismic Mounting.

**Factory start-up** - (Includes one additional year of warranty. See warranty conditions.

**Warranty** Limited manufacturer warranty is one-year, parts and labor, for system electronics or two-year with factory start-up program. Battery warranty is one year full plus 9 years pro-rata for a total of 10 years, under normal operating conditions. System must be put in service within 6 months from ship date in order to validate warranty. 2- Consult factory for other type batteries than the standard one.

Detailed warranty terms located on page 182 or online at: [www.lightalarms.com](http://www.lightalarms.com)

**Single line diagram**

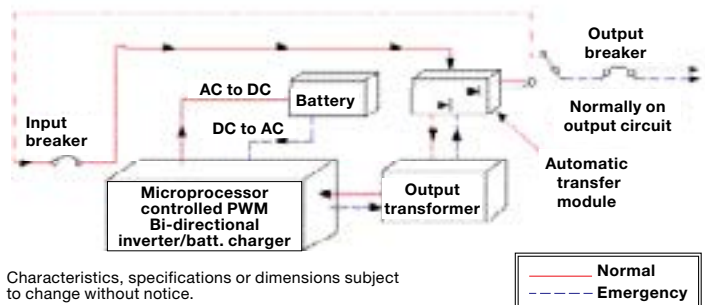

Characteristics, specifications or dimensions subject to change without notice.