



# SEVERE™ VH SERIES

Class I, Division 2 Housing  
6V-18W & 12V up to 72W Capacities  
Lead-Calcium battery

## FEATURES

### Housing

- Class I Division 2, Groups A, B, C and D
- Lamps shielded by a clear vandal-resistant polycarbonate cover
- Two fully tool-less adjustable glare-free MR16 lighting heads
- Front and Back plates are of a heavy duty 1/8 inch thick aluminum
- Stainless steel tamper-proof screws

### Mounting:

- Surface Wall Mount Only
- Includes mounting lugs on each side of the housing
- Backplate included universal knock-outs to mount to any standard 4" junction box
- 1/2 inch Conduit knock-outs entry on both sides and top of housing

### Choice of Lamp Type

- MR16 Halogen Lamp, 12V-12W or 12V-20W
- MR16 LED Lamp, 6V-4W, 12V-4W or 12V-5W

### Electronics

- Micro-controller based charging circuit
- Automatic, temperature compensated, pulse type charger
- High capacity, automatic, solid-state transfer "spark-free"
- Low voltage disconnect prevents over discharge of battery
- Battery lock-out prevents battery discharge during installation
- Fused output circuit

### Improved Diagnostics

- Units equipped with Improved Diagnostics shall self-test, by simulating a power failure, in accordance with NFPA101, Life Safety Code minimum 30 seconds every 30 days, 30 minutes every six months and 90 minutes annually. For complete information refer to page 8.

### Nexus® Option

- Units equipped with NEXUS® self-testing monitoring system circuitry shall self-test, in accordance with NFPA101, Life Safety Code minimum 30 seconds every 30 days, 30 minutes every six months and 90 minutes annually as well as keep a history of all testing logs, plus feature a real-time diagnostics, as well as, be able to locate exact fixture location while notifying service personnel to the status of the fixture via email notification. For complete information refer to page 4-5.

### Controls

- Red AC-On LED indicates Ac power is on
- Magnetically operated test switch allows for quick operational check of entire system

### Sealed-Maintenance Free Battery

- 6 or 12V Lead-Calcium battery

### Approvals

- CSA-US approved
- Evaluated to UL924 Standard
- Evaluated to the UL 844 Standard for Class I Division 2, Groups A, B, C and D
- NEC, OSHA and NEMA compliant for above Classes and Groups
- Ambient temperature 50-104F (10-40C)
- Certified temperature codes for several emergency lamp types
- Certified for use in damp and wet locations

### Warranty (subject to proper installation and maintenance)

- Unit has a three year full warranty (excluding LED lamps and fuses)<sup>1</sup>
- Lead Calcium Battery has a 3 year full, plus 3 year pro-rata warranty

<sup>1</sup> For LED lamps warranty, refer to page 168 paragraph 3.2

## SPECIFICATIONS

Supply and install Lightalarms® Severe™ VH Series.

The emergency lighting unit shall be a self-contained fixture including a sealed maintenance-free Lead-Calcium battery of 6V or 12V with watts as specified. The unit shall supply the rated wattage load for a minimum of 90 minutes to 87-1/2% of rated battery voltage. The unit shall be rated 120/277VAC, 60 Hz and be CSA-US approved. The unit shall be certified for use in Hazardous locations: Class I Division 2, Groups A, B, C and D.

The unit charger shall utilize a micro-controller which samples the battery in relation to the ambient temperature, state of charge and input voltage fluctuations. The charger shall be current limited, temperature compensated, and short-circuit protected. The unit shall be furnished with an electronic lockout circuit which will connect the battery when the AC circuit is activated, and an electronic brownout circuit which will activate the unit when utility power dips below 80-85% of nominal voltage. A low voltage battery protection circuit shall be provided and will disconnect the load and circuitry from the battery when it reaches 87-1/2% of its nominal voltage. The unit shall be capable of full recharge in compliance with UL924 specifications. The unit shall be furnished with sealed dust-tight relay, Green LED pilot light to indicate AC-On and a magnetic test switch allows for quick operational check of entire system.

The Improved Diagnostics shall continuously monitor every critical function of the unit. If a malfunction occurs, the green pilot indicator LED located on the unit will change to red and begin to a flash, indicating a fault. If an audible optional alarm is specified, a high-pitch audible alarm will sound as well as the illuminating the fault pilot indicator. A detailed diagnostic legend next to the pilot indicator LED provides fault identification as battery, charger circuitry or lamps failure. The microcontroller shall automatic self-test, by simulating a power failure, in accordance with NFPA101, Life Safety Code for one minute every 30 days, 30 minutes every six months and 90 minutes annually.

The frame shall be of industrial grade polyvinyl chloride with gaskets around both sides of the frame contour. The frame shall be covered by two plates made of 1/8 inch thick aluminum sheets. The back plate shall include four keyholes for wall mount application. The front plate shall include water lenses for AC On and Service required pilot light indicators. Two fully tool-less adjustable glare-free MR16 lighting heads covered by a shock-absorbent clear vandal-resistant polycarbonate cover.

Every Severe™ VH Series unit shall be fully warranted for three years, subject to proper installation and maintenance.

Unit shall be Lightalarms® catalog number \_\_\_\_\_.

## ACCESSORIES (Order as a separate item)

Wire Guard	WG3-L
------------	-------

## SEVERE™ CLASS 1, DIVISION 2 FAMILY

The Severe™ VH Battery Unit is part of the Severe™ family of Class I Division 2 rated emergency lighting products. Extremely resistant to strong impacts, vibrations and variations in temperature, this family of products is ideally suited for areas with the risk of the presence of flammable gases, or vapors or liquids able to create an explosive gas atmosphere.



Severe™ XVHZ & XVEHZ Exit Series  
p.44



Severe™ XVH Combo Series  
p.46



Severe™ ELF651 Remote Series  
p.113



TYPE \_\_\_\_\_

CATALOG # \_\_\_\_\_

NOTES \_\_\_\_\_

Designed to meet the specific requirements of Class I, Division 2, Groups A, B, C, and D, hazardous areas



## DIMENSIONS

Dimensions are approximate and subject to change.

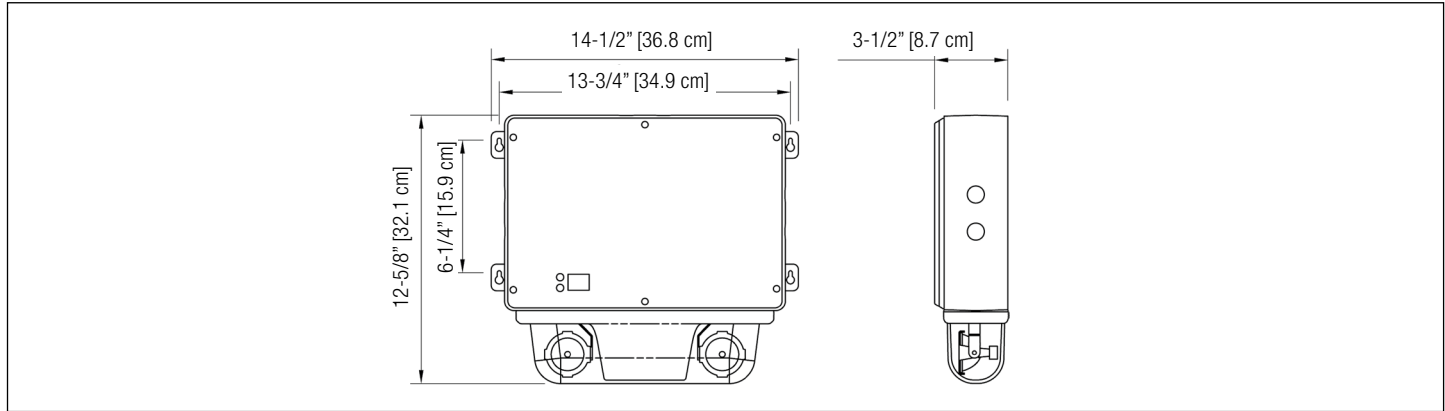

## TEMPERATURE CODES: MR16LED LAMPS

LAMPS SUFFIX	VOLTAGE	WATTAGE	TEMPERATURE CODE	MAX. TEMPERATURE	REPLACEMENT #
LD1	6	4	T4A	120°C	580.0097-L
LD7	12	4	T4A	120°C	580.0093-L
LD9	12	5	T4A	120°C	580.0104-L

## MR16 HALOGEN LAMPS

LAMPS SUFFIX	VOLTAGE	WATTAGE	TEMPERATURE CODE	MAX. TEMPERATURE	REPLACEMENT #
M12	12	12	T3C	180°C	580.0080-L
MH20	12	20	T2C	230°C	580.0168-L

## POWER CONSUMPTION / UNIT RATING CHART

SERIES	DC SPECS						AC SPECS	
	BATTERY TYPE	DC VOLTAGE	87.5% BATTERY CAPACITY (IN WATTS) <sup>1</sup>				UNITS DUAL VOLTAGE <sup>2</sup>	CURRENT MAXIMUM
			90 MIN.	2 HRS.	3 HRS.	4 HRS.		
VHG1	Lead-Calcium	6V	18	12	9	0	120/277VAC	.17A/.09A
VH12G1		12V	36	27	18	14		
VH12G2		12V	60	45	30	24	120VAC 277VAC	.3A .15A
VH12G3		12V	72	54	36	28		

<sup>1</sup> National Electrical Code Specification

<sup>2</sup> All units 120/277 dual voltage, information based on wiring to specific voltage type

## ORDERING FORMAT

# OF HEADS	SERIES	LAMP TYPE <sup>1</sup>	COLOR	OPTIONS
0= No head 2= 2 Heads	VHG1= 6V-18W VH12G1= 12V-36W VH12G2= 12V-60W VH12G3= 12V-72W	<b>MR16 Halogen Lamp</b> M10= 12V-10W M12= 12V-12W MH20= 12V-20W  <b>MR16 LED Lamp</b> LD1= 6V-4W MR16 LED LD7= 12V-4W MR16 LED LD9= 12V-5W MR16 LED	G= Grey	<b>Blank</b> = Improved Diagnostics (included standard - non audible) <b>-DA</b> = Improved Diagnostics (optional - audible) <sup>1</sup> <b>-NEX</b> = Nexus® Wired Compatible <sup>2</sup> <b>-NEXRF</b> = Nexus® Wireless Compatible <sup>2</sup> <b>-T1</b> = Time Delay (5 minute) <b>-T2</b> = Time Delay (10 minute) <b>-T3</b> = Time Delay (15 minute)

<sup>1</sup> No other lamp types available for this Series, for complete information on these lamp types refer to page 153.

<sup>1</sup> -ID & -IDNA include a time delay feature that can be enabled/disabled in the field or set by the factory by including -ID-TD\* or -IDNA-TD\*  
<sup>2</sup> -NEX & -NEXRF is CSA-US approved only.  
 Consult your sales representative

EXAMPLE: 2VHG1LD1G