



# Phantom – Emergency Lighting



**WARNING:**  
Risk of Electrical Shock.  
Disconnect Power before Installation.



## IMPORTANT SAFEGUARDS

When using electrical equipment, basic safety precautions should always be followed including the following:

## READ AND FOLLOW ALL SAFETY INSTRUCTIONS

1. All servicing should be performed by qualified service personnel.
2. All unused wires must be insulated to prevent shorting.
3. Do not use outdoors.
4. Do not let power supply cords touch hot surfaces.
5. Do not mount near gas or electric heaters.
6. Use caution when handling batteries. Avoid possible shorting.
7. Equipment should be mounted in locations and at heights where it will not readily be subjected to tampering by unauthorized personnel.
8. The use of accessory equipment not recommended by the manufacturer may cause an unsafe condition.
9. Do not use this equipment for other than intended use.
10. Unit to be installed only as per configuration described in this instruction manual.

## SAVE THESE INSTRUCTIONS

### Installation Instructions



**IMPORTANT:**

Install fixture/lamp type combination no higher than the maximum mounting heights as stipulated in the "Lamp Mounting Height Cross-reference Table" (P/N 750.1924). Refer to "Technical Information" section of our website.

Turn off AC power.

#### Wall Mount Back-Box Installation (Figure 1)

1. Knock out the hole(s) on top of the back-box for incoming cable(s) (AC line and/or DC emergency line). (Figure 1)
2. Position the back-box at the desired location to be flush with the front edge of the stud observing mounting orientation (Figure 1).
3. Use appropriate fasteners (not supplied) to mount the back-box on the stud (Figure 1).
4. Connect the conduit to the K.O.'s on the top of the box.
5. Pull 10" of wire into the box for the final electrical connections.
6. Install the drywall over the back-box.
7. Locate the center of the opening and rout out drywall. Follow the outline of the opening in the back-box.

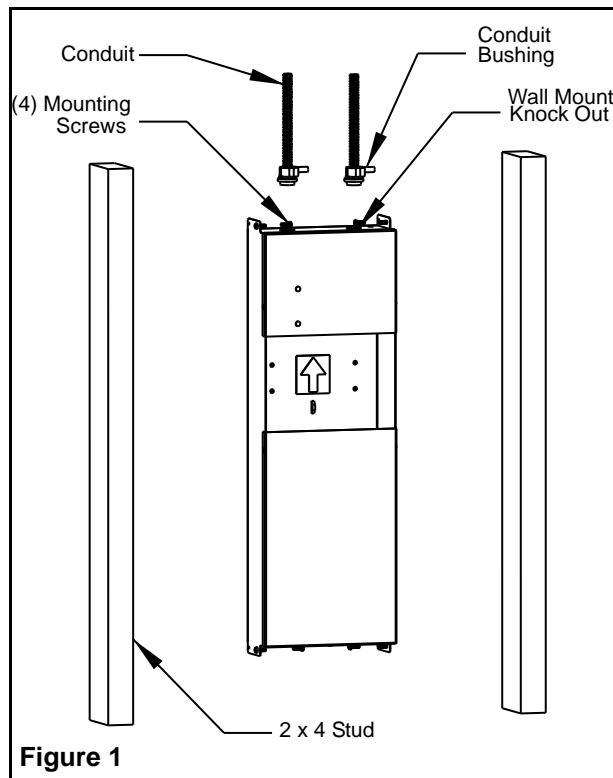

Figure 1

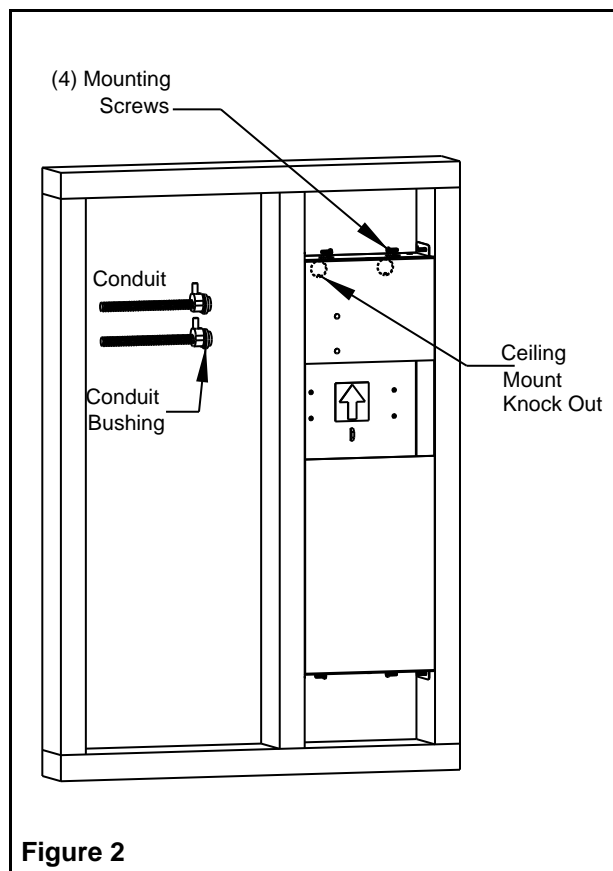

Figure 2

### Drywall Ceiling Back-Box Installation (Figure 2)

1. Knock out the hole(s) on the back-box for incoming cable(s). (AC line and/or DC emergency line, Figure 2).
2. Position the back-box at the desired location to be flush with the front edge of the joist, observing mounting orientation (Figure 2).
3. Mount the back-box on the joist using screws (not supplied).
4. Frame the back-box as shown in Figure 2. Check for proper installation.
5. Follow instructions 5 to 9 of the Wall Mount Back-Box Installation.

### T-bar Ceiling Back-Box Installation (Figure 3)

1. Knock out the hole(s) on the rear of the back-box for incoming cable(s). (AC line and/or DC emergency line) (Figure 3).
2. Mount the supplied T-bar brackets on the four tabs as shown in the Figure 3. Use position #1 hole for 1" T-bar and position #2 hole for 1.5" T-bar. For each position move the bracket to adjust the slot hole(s) for 1/2" or 5/8" ceiling tile thickness to locate the back-box flush with the back face of the ceiling tile. Tighten the screw(s).
3. Position the back-box at the desired location across the ceiling T-bars (Figure 4). Secure the Back-Box to the ceiling joists by chains, or "pencil rod" wire to support the unit.
4. Follow instructions 5 to 7 of the Wall Mount Back Box Installation.
5. Install the ceiling tile in position. There should not be any gap between the back-box and the tile if the mounting brackets have been installed properly.
6. Locate the center of the opening and route out the ceiling tile. Follow the outline of the opening of the back-box.

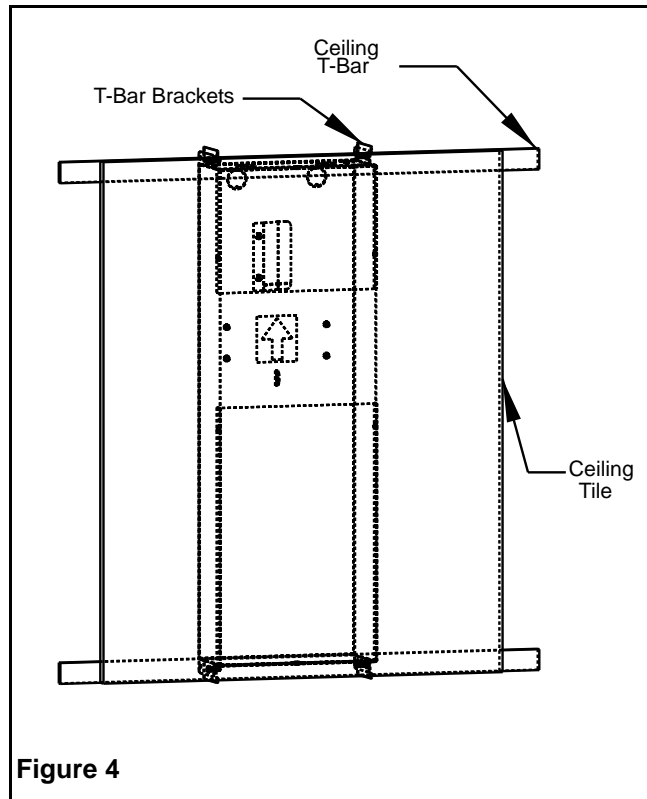
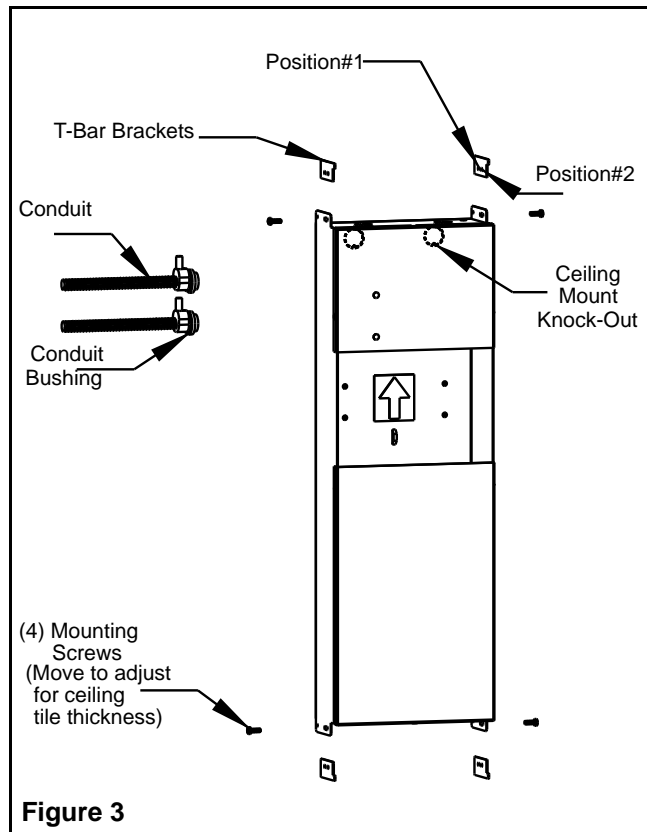

### Charger Module Installation (Figure 6)

1. Pull out the electrical cables from the back box and cut the wires to leave 2 to 3 inches of wire outside the back-box.
2. Connect the GREEN wires from the charger module and the back-box to the GROUND supply wire.
3. For 120VAC connect the BLACK wire (labeled 120VAC) from the charger module to Line and the WHITE wire (labeled neutral) to Neutral.
4. For 277VAC connect the ORANGE wire (labeled 277VAC) from the charger module to Line and the WHITE wire (labeled Neutral) to Neutral.
5. For 347VAC connect the RED wire (labeled 347VAC) from the charger module to Line and the WHITE (labeled Neutral) to Neutral.
6. If there are any remote heads to be connected to the unit, connect the RED wire (labeled L+) and the BLUE wire (labeled L-) to the load out going wires.
7. Caution: failure to cap the wires may cause an unsafe condition
8. Place the charger module in the back-box with the outgoing wires on the right side. Enter the module at an angle, to bypass the flexible bracket in the back-box; then slide the module upward, until it is latched by the flexible bracket. (Figure 6).
9. Check for secure installation.

### Battery Installation (Figure 7a, b, c)

This equipment is provided with a battery module made up of one, two or three sealed batteries, depending on the rated capacity. Follow the instructions below for the battery module configuration of your unit.

#### One-battery module (Figure 7a)

1. Take the 2 wires from the charger module (labeled: BATTERY CONNECTION) pass them under the tie-wraps and connect them to the battery (RED to positive and BLUE to negative).
2. Tighten the tie-wrap next to the battery terminals in order to secure the wires in place.
3. Place the battery in the lower compartment of the back-box, ensuring that the battery terminals are facing the left and the wires on the right side of the back box.
4. Place the two wires under the stopper bracket then slide the bracket towards the left into the slot all the way in the back-box (Figure 8).

#### Two-battery module (Figure 7b)

1. Take the battery with the wiring harness attached. Verify if the wire harness is well connected to the battery tab and tightly secured with the tie-wrap.
2. Place the battery in the lower compartment of the back-box, with the tabs to the left and the wire harness to the right side.
3. Take the second battery and run the wires with the female connectors under the tie-wraps and connect them to the battery (RED to positive and BLUE to negative).
4. Tighten the tie-wrap next to the battery terminals in order to secure the wires in place.
5. Place the second battery in the same direction as first battery.
6. Connect the male connectors of the wiring harness to the RED and BLUE wires from the charger module, as per the label indication (RED wire to RED wire; BLUE wire to BLUE wire).
7. Place the two wires under the stopper bracket then slide the bracket towards the left into the slot all the way in the back-box (Figure 8).

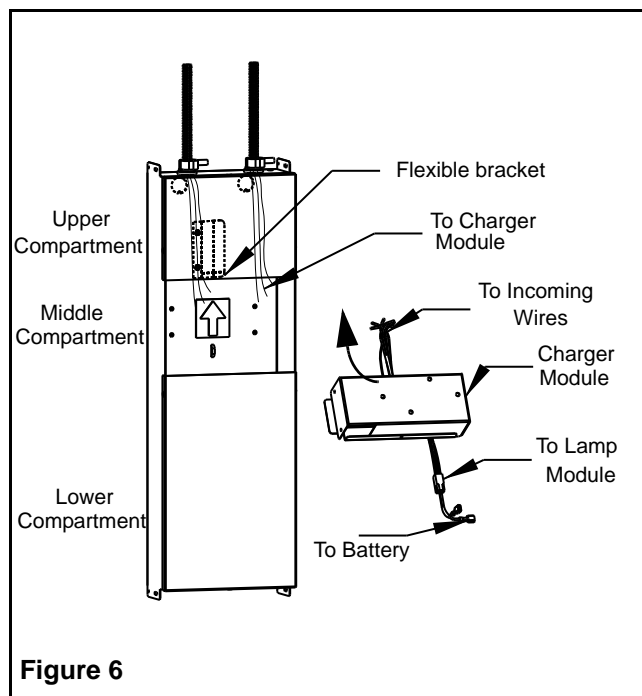
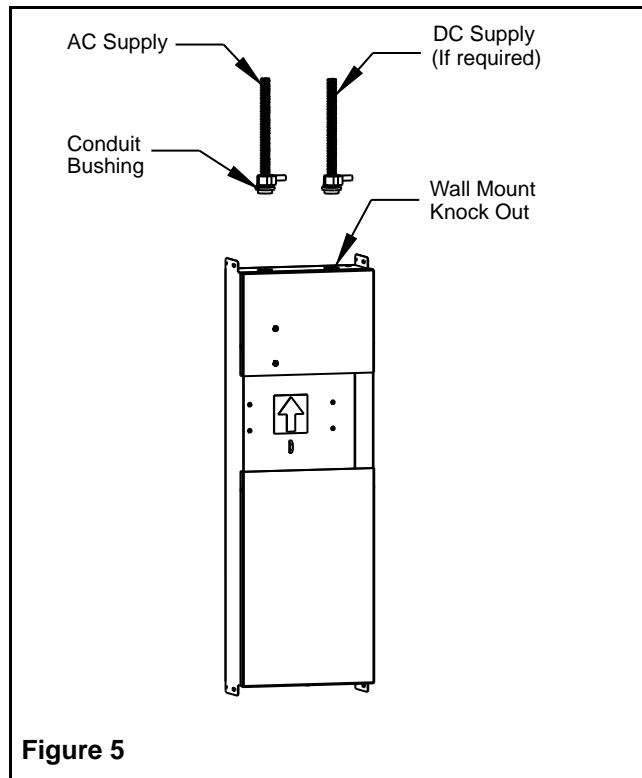

### Three-battery module (Figure 7c)

1. Take the battery with the wiring harness attached. Verify if the wire harness is well connected to the battery tab and tightly secured with the tie-wrap.
2. Place the battery in the lower compartment of the back-box, with the tabs to the left and the wire harness to the right side.
3. Take the second battery and run the wires with the female connectors under the tie-wraps and connect them to the battery (RED to positive and BLUE to negative).
4. Tighten the tie-wrap next to the battery terminals in order to secure the wires in place.
5. Place this battery in the same direction as first battery.
6. Take the third battery and run the wires with the female connectors under the tie-wraps and connect them to the battery (RED to positive and BLUE to negative). Then follow the same instructions as in steps 4-5 above.
7. Connect the male connectors of the wiring harness to the RED and BLUE wires from the charger module, as per the label indication (RED wire to RED wire; BLUE wire to BLUE wire).
8. Place the two wires under the stopper bracket then slide the bracket towards the left into the slot all the way in the back-box (Figure 8).

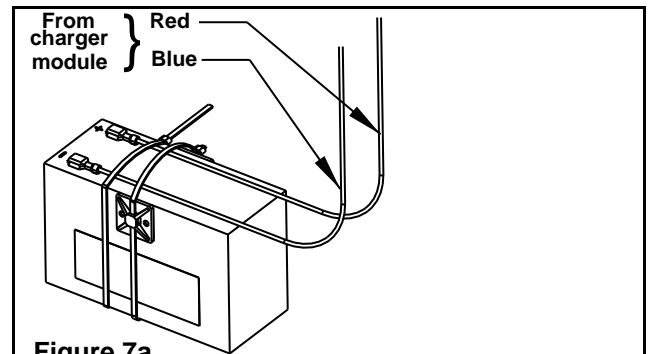

Figure 7a

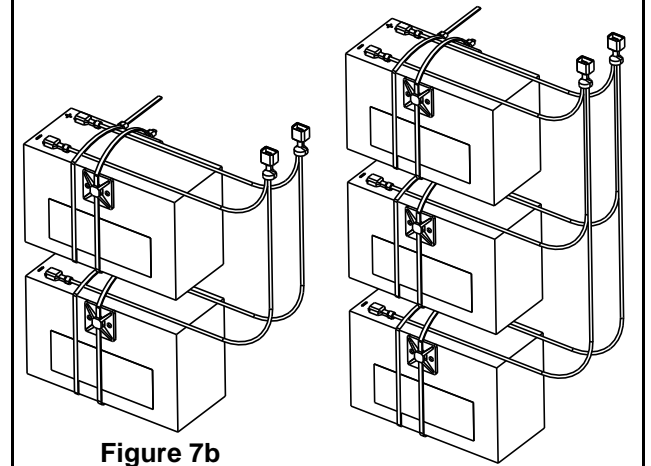

Figure 7b

Figure 7c

Figure 7 a,b,c

### Lamp Module Installation (Figure 8)

1. Install the four screws (provided with the stopper bracket) 2-3 threads into the pem-studs of the back-box.
2. Hold the lamp module by the harness and connect it to the 4-pin connector of the charger module.
3. Push on one side of the door of the lamp module to open it half-way and identify the four key holes in the housing.
4. Mount the lamp module by aligning it with the screws in the back-box. Slide the lamp module so that the head of the screws are in the slotted part of the key hole. (Make sure the harness and connector are placed in the space provided between the back-box and the charger module.)
5. Align the lamp module on the wall then secure it to the back-box by tightening the four screws (located in the key holes) until its trim is flush with the wall. (For easy access to the screws the door can be rotated one full turn of 360 degrees.)
6. Orient the two lamps in their swivels and verify that they are plugged into the sockets.
7. Close the door and make sure that it is flush with the trim.

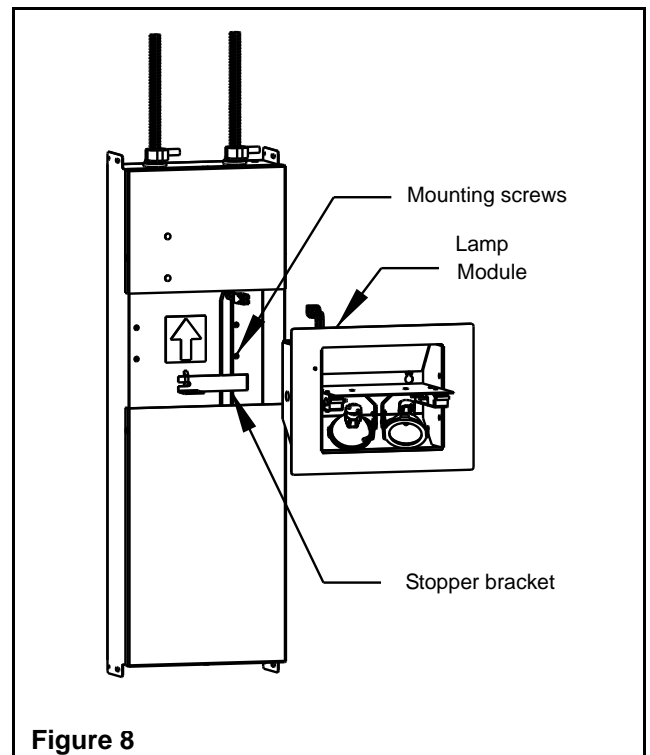

Figure 8

### Testing the Equipment

1. Energize AC.
2. The recessed pilot light/test switch will light in green.
3. Push the test button. The door will open and the lamps will illuminate for one minute, then the door will close. Orient the lamps to the desired position at this time. If more time is needed, push the test button again.
4. The unit requires no maintenance, but should be tested regularly in accordance with the local codes.